

**IN THE GENERAL DIVISION OF  
THE HIGH COURT OF THE REPUBLIC OF SINGAPORE**

**[2022] SGHC 257**

Suit No 1086 of 2019

Between

ICOP Construction (SG) Pte  
Ltd

*... Plaintiff*

And

Tiong Seng Civil Engineering  
Pte Ltd

*... Defendant*

**Counterclaim**

Between

Tiong Seng Civil Engineering  
Pte Ltd

*... Plaintiff in Counterclaim*

And

ICOP Construction (SG) Pte  
Ltd

*... Defendant in Counterclaim*

---

**JUDGMENT**

---

[Building and Construction Law — Building and construction contracts —  
Measurement contracts]  
[Building and Construction Law — Contractors' duties]  
[Building and Construction Law — Damages]  
[Building and Construction Law — Employers' duties]  
[Building and Construction Law — Quantum meruit]  
[Building and Construction Law — Scope of works — Variations]  
[Building and Construction Law — Termination]  
[Credit and Security — Performance bond]

## CONTENTS

---

<b>INTRODUCTION</b> .....	<b>1</b>
<b>BACKGROUND</b> .....	<b>2</b>
<b>OVERVIEW OF THE ISSUES</b> .....	<b>7</b>
<b>ISSUE 1: HYDRAULIC JOINTS FOR DN1200MM PIPELINE</b> .....	<b>12</b>
<b>ISSUE 2: HYDRAULIC JOINTS FOR DN1600MM PIPELINE</b> .....	<b>19</b>
<b>ISSUE 3: HEADWALL DEFECTS IN SHAFT P5-2</b> .....	<b>23</b>
<b>ISSUE 4: DEFECTS IN SHAFT P5-1</b> .....	<b>24</b>
<b>ISSUE 5: ICOP’S UNPAID WORKS</b> .....	<b>31</b>
<b>ISSUE 6: ADDITIONAL WORKS AND SERVICES</b> .....	<b>32</b>
<b>ISSUE 7: THE DELAY CLAIM AND COUNTERCLAIM</b> .....	<b>33</b>
<b>PRELIMINARY: ICOP’S UNPLEADED CLAIM FOR 259 DAYS OF DELAY</b> .....	<b>34</b>
<b>APPLICABLE BASELINE PROGRAMME</b> .....	<b>35</b>
<b>OVERVIEW OF DELAYS IN ISSUE</b> .....	<b>39</b>
<b>THE WORKSITE READINESS AND HANDOVER ISSUE</b> .....	<b>45</b>
<b>THE AUTHORITY APPROVALS ISSUE</b> .....	<b>50</b>
<b>THE HEADWALL ISSUE</b> .....	<b>57</b>
<b>THE NOISE RESTRICTIONS ISSUE</b> .....	<b>60</b>
<b>THE INSUFFICIENT PIPES ISSUE</b> .....	<b>64</b>
<b>THE POOR-QUALITY PIPES ISSUE</b> .....	<b>70</b>
<b>THE WASTE DISPOSAL ISSUE</b> .....	<b>71</b>

THE UNPLANNED CUTTERHEAD INSPECTION ISSUE.....	71
THE SLOW PIPE JACKING ISSUE .....	72
THE SLOW DEMOBILISATION ISSUE .....	75
THE REMOVAL OF THE MTBM ISSUE.....	77
SUMMARY OF CONCLUSIONS ON ISSUE 7 .....	78
<b>ISSUE 8: ICOP’S TERMINATION OF THE SUBCONTRACT .....</b>	<b>80</b>
WHETHER ICOP’S TERMINATION OF THE SUBCONTRACT WAS LAWFUL .....	80
ICOP’S CLAIM FOR OUTSTANDING SUMS DUE AND RETENTION SUMS .....	82
<b>ISSUE 9: THE PERFORMANCE BOND .....</b>	<b>86</b>
<b>ISSUE 10: COUNTERCLAIM FOR DIESEL .....</b>	<b>87</b>
<b>ISSUE 11: COUNTERCLAIM FOR SLURRY DISPOSAL .....</b>	<b>88</b>
<b>CONCLUSION AND ORDERS .....</b>	<b>89</b>
<b>ANNEX 1: APPLICABLE BASELINE PROGRAMME.....</b>	<b>93</b>

**This judgment is subject to final editorial corrections approved by the court and/or redaction pursuant to the publisher's duty in compliance with the law, for publication in LawNet and/or the Singapore Law Reports.**

**ICOP Construction (SG) Pte Ltd**  
**v**  
**Tiong Seng Civil Engineering Pte Ltd**

**[2022] SGHC 257**

General Division of the High Court — Suit No 1086 of 2019

Lee Seiu Kin J

19, 21, 22, 26–29 July, 6, 8, 11, 13, 14, 20, 22, 27, 28 October 2021,  
18 February 2022

12 October 2022

Judgment reserved.

**Lee Seiu Kin J:**

**Introduction**

1 The defendant subcontracted the performance of pipe construction works to the plaintiff. Various disputes arose in the course of the performance of these works – which were ultimately only part-completed – and the plaintiff eventually terminated the subcontract. In this suit, the plaintiff seeks to recover: (a) payment for work it carried out; (b) costs it incurred in connection with alleged contractual variations as well as from the provision of additional equipment and services at the defendant's request; (c) damages caused by the defendant's failure to meet project specifications as well as delays it allegedly caused; and (d) monies paid under performance and advance payment bonds. The defendant disputes liability entirely and, amongst other counterclaims,

seeks to recover damages on the basis that delays were instead caused by the plaintiff.

## **Background**

2 The plaintiff, ICOP Construction (SG) Pte Ltd (“ICOP”), is a company incorporated in Singapore. It is in the business of constructing, amongst other things, water, gas and sewage pipelines. Tiong Seng Civil Engineering Pte Ltd (“TSCE”), the defendant, was also incorporated in Singapore, and its business is the provision of infrastructure engineering design and consultancy services, as well as the construction of civil engineering projects.<sup>1</sup> TSCE belonged to a group of companies which included Tiong Seng Contractors Pte Ltd (“TSC”).

3 In or around June 2016, TSC was engaged by the Public Utilities Board (the “PUB”) to construct a potable water pipeline (the “Project”).<sup>2</sup> TSC subcontracted the Project wholly to TSCE. Around May 2017, TSCE entered into a subcontract with ICOP for the performance of microtunnelling works which constitute part of the Project. This was done through the execution of a letter of award as amended by a supplemental letter (the “LOA”), both of which were dated 15 April 2017.<sup>3</sup> The terms of their subcontract were captured in several documents set out in cl 1.1 of the LOA<sup>4</sup> and, collectively, I will refer to them as the “Subcontract”. In the course of this judgment, I will reproduce the relevant terms reflected in the Subcontract, as necessary.

---

<sup>1</sup> Statement of Claim (Amendment No 2) (9 Sep 2020) (“SOC2”) at paras 1–2; Defence and Counterclaim (Amendment No 4) (22 Jul 2021) (“D&CC4”) at para 2.

<sup>2</sup> SOC2 at para 3; D&CC4 at para 3.

<sup>3</sup> SOC2 at para 4; D&CC4 at para 4.

<sup>4</sup> Agreed Bundle of Documents (12 Jul 2021) (“ABOD”) (Vol 16) at pp 286–287.

4 The Project, which was titled “Proposed 1600mm diameter pipeline from AYE/Henderson Road to River Valley Road”, was part of a larger project for the construction of potable water pipelines from Jalan Kampung Chantek to Marina South and River Valley Road. As far as the Project was concerned, ICOP was engaged to install: “124m of DN1200mm Reinforced Concrete Composite Pipe with built in Mild Steel Collar” and “2229m of DN1600mm” of the same type of pipe. The installation method was microtunnelling, and this was to be carried out in four drives: the first was for the installation of the shorter DN1200mm pipeline (the “DN1200mm Pipeline”), and the other three drives were to install the longer DN1600mm pipeline (the “DN1600mm Pipeline”).<sup>5</sup> I should also add that “DN” (Diameter Nominal) refers to the internal diameter of the pipe.

5 Briefly, microtunnelling is a method of installing pipelines which entails “thrusting pipes through the ground as controlled excavation is undertaken at the cutter-face of the microtunnel boring machine (the “MTBM”)”. An illustration and description of a typical microtunnelling setup is assistive:<sup>6</sup>

---

<sup>5</sup> Consolidated Bundle of Affidavits of Evidence-in-Chief (12 Jul 2021) (“CBAEIC”) (Vol 1) at pp 31–32, paras 64–66 (Cheng Ching Keong’s AEIC); CBAEIC (Vol 12) at p 8764, para 14 (Jung Jae Hun’s AEIC); ABOD (Vol 16) at p 83.

<sup>6</sup> CBAEIC (Vol 1) at pp 11–13, paras 9–14 (Cheng Ching Keong’s AEIC).

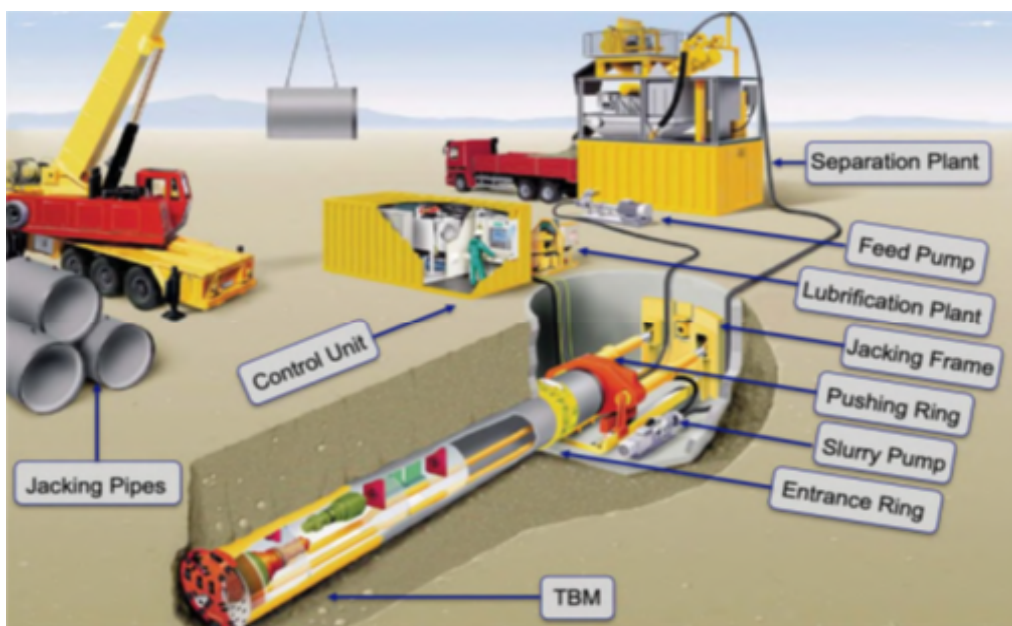

6 ICOP’s further description of the process, as given by their main factual witness, Cheng Ching Keong (“Dato Cheng”), is as follows:

In essence, two vertical shafts are constructed from the road level to the depth of the proposed pipeline. One shaft is called the launching or jacking shaft. The other is called the receiving or exit shaft. Ideally, microtunnelling works for each “drive” of the pipeline (*i.e.*, the distance between the launching shaft and the receiving shaft) should be carried out round-the-clock to maximise efficiency and productivity, with the MTBM and the pipeline advancing continuously from the launching shaft to the receiving shaft. ...

The rotating cutting wheel of the MTBM excavates the material at the tunnel face. Rock and stones are ground down and transferred to the slurry circuit where it is transported to the separation plant on the surface. At the separation plant, the excavated material is separated from the slurry.

The MTBM and the pipeline advance continuously with the help of the jacking frame. Each pipe section is lowered into the shaft, one after the other. Once a pipe section has been jacked to the maximum extent possible by the jacking frame, a new pipe section is then lowered into the shaft and the process is repeated. ... [A] diagram setting out the typical microtunnelling sequence is set out below:



### PIPE JACKING SEQUENCE

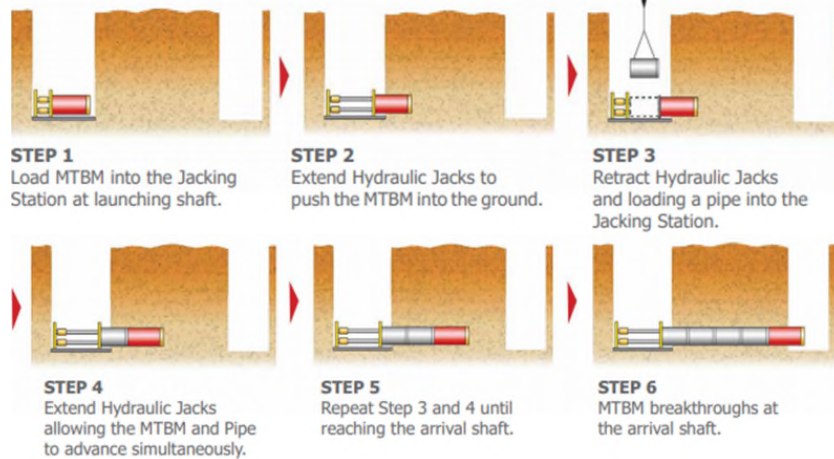

Once the MTBM breaks through and into the receiving shaft, it is then lifted out (in whole) by a crane so that it can be used in subsequent microtunnelling works.

7 To this, I should call to attention three other points regarding the process of microtunnelling which are relevant in this dispute. First, pressure is transferred from the jacking frame through each pipe section. This being the case, it is clearly necessary for *something* to ensure the smooth transfer of pressure between each section. Ordinarily, timber pressure transfer rings (also known as “chipboard”) are used. However, ICOP also has superior hydraulic joints which enable pressure to be transferred more effectively, and, therefore, pipelines can be installed with a tighter curvature.<sup>7</sup> Second, when exiting the launching shaft, the MTBM needs to break through a wall. This is called the “headwall”, and at its centre is a “soft eye”, a weak section of concrete and a watertight seal which allows the MTBM to be launched without water or other material flooding into the shaft. This function requires the seal to be able to sustain a certain amount of pressure, depending on various factors.<sup>8</sup> Lastly, upon

<sup>7</sup> CBAEIC (Vol 1) at pp 34–35, paras 71–73 (Cheng Ching Keong’s AEIC); also see ABOD (Vol 16) at p 132, cl 12.15.2.

<sup>8</sup> CBAEIC (Vol 4) at pp 2429–2433, paras 32–43 (Nicolò Alberini’s AEIC).

reaching the receiving shaft, the MTBM needs to be lifted out as a whole by crane.<sup>9</sup> Therefore, the whole length of the shaft needs to be free from protrusions<sup>10</sup> that would block the path of the MTBM as it is being lifted out. Should there be obstructions, the MTBM would need to be dismantled prior to being removed, and this would result in additional costs.<sup>11</sup>

8 This general description of the Project and of how microtunnelling works are carried out is sufficient, at this point, to understand the nature of the parties' dispute. As and when further details are necessary to understand the specific issues before me, I shall then set them out.

9 I will not dedicate a section in this judgment to the general context and chronology of the parties' contractual relationship. It suffices to note that in the middle of 2017, ICOP commenced the first drive to install the DN1200mm Pipeline ("Drive 1"); then in 2018, it carried out the second drive to install a section of the DN1600mm Pipeline ("Drive 2"). During Drive 2, the parties were already facing tensions and disagreements. So much so that after Drive 2 in March 2019, and before the commencement of the third drive, ICOP considered itself justified in terminating the Subcontract. Interspersed between these three key events were – obviously – many important sub-events, activities and communications. These, however, are better dealt with together with the merits of the various claims and counterclaims brought by ICOP and TSCE respectively. This is because, for the most part, the issues before me are relatively discrete.

---

<sup>9</sup> CBAEIC (Vol 4) at p 2425, para 16 (Nicolò Alberini's AEIC).

<sup>10</sup> CBAEIC (Vol 4) at p 2860 (Nicolò Alberini's AEIC).

<sup>11</sup> CBAEIC (Vol 4) at pp 2438–2444, paras 60–82 (Nicolò Alberini's AEIC).

10 On this note, I turn to those issues.

### **Overview of the issues**

11 The issues to be determined are as follows:

(a) Issue 1: Whether there was a contractual variation which enables ICOP to recover additional costs it incurred from using hydraulic joints for the DN1200mm Pipeline instead of cheaper chipboard. On ICOP’s case, it incurred \$77,004 in additional costs from the use of hydraulic joints.<sup>12</sup>

(b) Issue 2: Whether there was a contractual variation to reduce the length of each pipe section for the DN1600mm Pipeline installed in Drive 2, such that ICOP is entitled to recover additional costs it incurred from having to use a greater number of hydraulic joints between each of those pipe sections.<sup>13</sup> On ICOP’s case, the additional costs incurred were \$95,087.98.

(c) Issue 3: Whether ICOP may recover, as damages, the additional costs it incurred as a result of TSCE’s alleged failure to construct the headwall for the launching shaft for Drive 2 (“Shaft P5-2”) in accordance with the specifications in the Subcontract or its duty of care. Specifically, it failed to construct a headwall that was capable of sustaining a maximum face pressure of 1.75 bar. Such costs – which ICOP claims amounts to \$94,821.30 – include those resulting from consequent delays caused by TSCE needing to reconstruct the headwall, as well as ICOP having to demobilise its equipment from Shaft P5-2

---

<sup>12</sup> SOC2 at paras 18–21.

<sup>13</sup> SOC2 at paras 12–17.

whilst it was being reconstructed and, subsequently, remobilise its equipment back to the shaft after the reconstruction of the headwall.<sup>14</sup>

(d) Issue 4: Whether ICOP may recover, as damages, the additional costs it incurred from having to extensively dismantle the MTBM before it could be extracted from the receiving shaft of Drive 2 (“Shaft P5-1”). ICOP claimed that these steps were required because TSCE failed to construct Shaft P5-1 in accordance with the specifications in the Subcontract, or its duty of care. On this, ICOP pleads that the losses it suffered amounts to \$104,154.54.<sup>15</sup>

(e) Issue 5: Whether TSCE is liable to pay ICOP for interim works it performed in December 2018 and January 2019 for Drive 2, pursuant to the Subcontract.<sup>16</sup> In respect of the works ICOP carried out in December 2018, ICOP claims \$335,376.06 and 7% goods and services tax (“GST”). As regards the works done in January 2019, ICOP claims \$255,762.61 and 7% GST. It bears noting, however, that these sums include ICOP’s separate claims for: (a) the cost of additional hydraulic joints used in the installation of the DN1600mm Pipeline (see Issue 2 at [11(b)] above); and (b) monies which ICOP alleges that TSCE wrongfully retained as security (see Issue 8 at [11(h)] below).<sup>17</sup> Accordingly, if ICOP does not succeed in respect of those issues, but succeeds on *this* issue, these sums will need to be deducted.

---

<sup>14</sup> SOC2 at paras 30–35.

<sup>15</sup> SOC2 at paras 22–29.

<sup>16</sup> SOC2 at paras 36–53.

<sup>17</sup> SOC2 at paras 45–46 and 52–53.

(f) Issue 6: Whether TSCE is liable to pay ICOP, on a *quantum meruit* basis, for additional works and services ICOP provided between June 2018 and May 2019 at TSCE’s request. The value of these works and services is said to amount to \$54,438.66.<sup>18</sup>

(g) Issue 7: Whether TSCE or ICOP is liable for various delays they each aver was caused by the other either in breach of the Subcontract or their respective duties of care in tort. On ICOP’s case, TSCE caused a 158-working day delay and, as a result, ICOP incurred \$2,516,774.98 in additional overheads and expenses. It is this sum which ICOP now seeks to recover.<sup>19</sup> On the opposite end, TSCE pleads that each of the delays in respect of which ICOP seeks to recover damages, was instead caused by ICOP’s own conduct. It is TSCE’s case that, in fact, ICOP had caused delays above and beyond those it seeks to attribute to TSCE. On its part, TSCE claims that ICOP was responsible for a 266-calendar day delay and, on this basis, it brings a primary counterclaim for liquidated damages for the period of the delay. In the alternative, on the basis that it is found to have delayed ICOP’s completion and time is set at large, TSCE contends that ICOP nevertheless exceeded the “reasonable time” it would have had and would still be liable for delay damages in excess of such time.<sup>20</sup>

(h) Issue 8: As mentioned at [8], ICOP terminated the Subcontract in 2019 and claims to have been entitled to do so on the basis that a clause of the Subcontract conferred a right of termination in the event that it: (a) fulfilled its obligations under the Subcontract; and (b) for

---

<sup>18</sup> SOC2 at paras 54–56.

<sup>19</sup> SOC2 at paras 57–65.

<sup>20</sup> D&CC4 at paras 54 and 63–68.

reasons beyond its control, it could not start or continue with its work in a timely manner. Given Issue 7, it is plainly in dispute whether ICOP had indeed “fulfilled its obligations under the [Subcontract]”.<sup>21</sup> In addition to this, however, it is also in dispute whether ICOP was unable to start or continue its work in a timely manner.<sup>22</sup> On the footing that it was legally entitled to terminate the Subcontract, ICOP claims \$72,711.80 as the balance sum owing for work done as well as \$61,517.48 which was retained as security. It is to be noted that a portion of these sums are contained within the sums claimed under Issue 5 (see [11(e)] above).<sup>23</sup> Conversely, if ICOP was not entitled to terminate – and its termination was therefore wrongful – TSCE seeks to recover damages for its loss of the benefit of ICOP’s services under the Subcontract.<sup>24</sup>

(i) Issue 9: This issue is connected to Issues 7 and 8. Pursuant to the Subcontract, ICOP furnished TSCE with a performance bond issued by the Singapore branch of BNP Paribas for the sum of \$570,000 (the “Performance Bond”). The relevant term of the Subcontract provided that TSCE was entitled to call on this Performance Bond “to make good any cost, expense, loss or damage sustained by [it] as a result of any breach of default under the [Subcontract] by [ICOP] or in satisfaction of any sum due from [ICOP] to TSCE”.<sup>25</sup> After ICOP terminated the Subcontract, TSCE called on the full sum of the Performance Bond and, to this, ICOP primarily pleads that such call was wrongful as it had not

---

<sup>21</sup> ABOD (Vol 16) at p 302, cl 6.

<sup>22</sup> SOC2 at para 68; D&CC4 at para 58.

<sup>23</sup> SOC2 at paras 70–71.

<sup>24</sup> D&CC4 at para 69.

<sup>25</sup> ABOD (Vol 16) at p 258, cl 6.4.

acted in breach of the Subcontract. In the alternative, ICOP avers that TSCE did not sustain any costs, expenses, losses or damages which entitled it to call on the Performance Bond. ICOP thus seeks recovery of the full sum of \$570,000.<sup>26</sup>

(j) Issue 10: Whether ICOP is liable to TSCE, either on a contractual or *quantum meruit* basis, for the cost of diesel supplied by the latter for the purposes of powering an electricity generator. It is TSCE's case that ICOP is liable for a sum of \$106,825.59.<sup>27</sup>

(k) Issue 11: Whether ICOP is liable to pay backcharges for the cost of slurry disposal paid for by TSCE. On TSCE's case, the amount owing is \$96,392.40.<sup>28</sup>

12 Before I turn to consider these 11 issues, it bears highlighting that ICOP had also furnished another bond issued by BNP Paribas for the sum of \$570,000 after it received advance payment for the same sum from TSCE (the "Advance Payment Bond").<sup>29</sup> Similar to its case in respect of the Performance Bond, ICOP pleads in its statement of claim ("SOC") that TSCE wrongfully called on this Advance Payment Bond after the Subcontract was terminated, though not for the full sum, but for \$385,360.41.<sup>30</sup> However, ICOP's SOC does not include a claim for damages for such wrongful call.<sup>31</sup> At trial<sup>32</sup> as well as in closing

---

<sup>26</sup> SOC2 at paras 72–75 and "Claims", number (11).

<sup>27</sup> D&CC4 at paras 70–71.

<sup>28</sup> Defendant's Closing Submissions (12 Jan 2022) ("DCS") at paras 601–603.

<sup>29</sup> SOC2 at para 73; ABOD (Vol 16) at p 259, cl 7.4.

<sup>30</sup> SOC2 at paras 74–75.

<sup>31</sup> See SOC2 from para 72 to end.

<sup>32</sup> Notes of Evidence ("NEs") (19 Jul 2021) at p 80 line 11 to p 81 line 16.

submissions, ICOP confirmed that no such claim was being made.<sup>33</sup> Thus, given that the bond was to secure an *advance payment*, the fact that the Advance Payment Bond was called on is largely inconsequential. The quantum of advance payment actually received by TSCE simply needs to be taken into account if I allow ICOP’s claims in respect of Issues 1, 2, 5, 6, 7, and 8, and thus hold TSCE liable for unpaid fees or damages.

13 I now deal with the 11 issues before me.

### **Issue 1: Hydraulic joints for DN1200mm Pipeline**

14 This claim mostly succeeds and I award ICOP \$76,538.25 (instead of the sum of \$77,004 it claims in its SOC).<sup>34</sup> The parties’ respective quantum experts – George Wall (“Mr Wall”) for ICOP and Alasdair Snadden (“Mr Snadden”) for TSCE – agree that \$76,538.25 is the sum to which ICOP should be entitled to recover in the event that I find in its favour.<sup>35</sup> I will now briefly set out the parties’ cases and explain my decision.

15 ICOP’s case is, essentially, that neither it nor TSCE contemplated the use of hydraulic joints for the DN1200mm Pipeline prior to the Subcontract being executed. Instead, they contemplated that this pipeline would be installed with: (a) 3.5m-long pipe sections; (b) a maximum radius of curvature at 300m; and (c) the gaps between the pipe sections filled with chipboard.<sup>36</sup> Subsequently, TSCE proposed that the length of pipe sections be reduced from 3.5m to 3.0m.

---

<sup>33</sup> Plaintiff’s Closing Submissions (12 Jan 2022) (“PCS”) at paras 371–372.

<sup>34</sup> SOC2 at para 21 and “Claims”, number (2).

<sup>35</sup> Joint Statement (Quantum) (8 Jul 2021) (“JS(Q)”) at para 2.2.2.

<sup>36</sup> SOC2 at para 18; PCS at paras 65–67 and 75.



ICOP advised that this was not permissible without the use of hydraulic joints<sup>37</sup> and, as a consequence, TSCE allegedly instructed ICOP to provide and install the DN1200mm Pipeline with such joints.<sup>38</sup> There is no dispute that hydraulic joints were ultimately used,<sup>39</sup> and, thus, ICOP claims that it is entitled to recover the costs associated with the provision of these joints.<sup>40</sup>

16 TSCE's essential response is three-pronged. First, it avers that the parties *expressly agreed* in the Subcontract that the pipe sections for the DN1200mm Pipeline would be 3.0m long.<sup>41</sup> Indeed, even before the Subcontract was signed, TSCE submits, ICOP knew that the pipe sections would be 3.0m and not 3.5m long. The import of this is that ICOP would have known of the difficulties of installing the pipeline within the maximum radius of curvature, and, thus, that hydraulic joints would likely be required. Given this, even if it is accepted that the parties agreed to use hydraulic joints for the DN1200mm Pipeline, this would not have been a variation in respect of which ICOP is entitled to claim *additional* sums. The price ICOP quoted, and which the parties agreed upon, would cover the costs of the hydraulic joints used.<sup>42</sup> Second, and in any case, TSCE avers that it was *ICOP* which suggested the use of hydraulic joints, not TSCE, and TSCE did not agree to any variation.<sup>43</sup> Third, and also in any case, TSCE submits that even if there was indeed a reduction in the length of pipe sections from 3.5m to 3.0m *and* a subsequent decision to use hydraulic joints

---

<sup>37</sup> CBAEIC (Vol 1) at pp 40–41 and 475 (Cheng Ching Keong's AEIC).

<sup>38</sup> SOC2 at para 19.

<sup>39</sup> SOC2 at para 20; D&CC4 at para 16.

<sup>40</sup> SOC2 at para 21.

<sup>41</sup> D&CC4 at para 14(1); DCS at paras 53–55.

<sup>42</sup> DCS at paras 63–68.

<sup>43</sup> D&CC4 at para 15; DCS at paras 56–62 and 74–78.

instead of chipboard, this constitutes a change in the microtunnelling methodology for which ICOP should bear the financial risk as the microtunnelling specialist.<sup>44</sup>

17 In my view, TSCE's third contention is without merit. The fact that ICOP was specialised in a particular area of construction bears no obvious connection with TSCE's claim that ICOP should bear the financial risk of costs arising from such specialist methodology. Ultimately, irrespective of whether a subcontractor is a specialist or not, the relationship it has with its main contractor is governed by ordinary principles of contract law (or particular principles within the field of construction contracts). And, in this light, a variation is a variation. If ICOP can establish one, it is entitled to its claim. For completeness, I should add that TSCE also did not cite any authority for its third contention.

18 With TSCE's third submission out of the way, there are to my mind, two key questions which need to be answered to resolve Issue 1. One, did the parties agree that the pipe sections for the DN1200mm Pipeline would be 3.5m or 3.0m, and, connectedly, did the parties contemplate the use of hydraulic joints on the original terms of the Subcontract as executed? Two, if the parties did not agree from the execution of the Subcontract that ICOP would use hydraulic joints in its installation of the DN1200mm Pipeline, did they subsequently agree to vary the Subcontract to provide for the use of such joints?

19 To determine the answer to the first question, reference needs to be made to various parts of the Subcontract:

---

<sup>44</sup> DCS at para 79.

(a) The method statement for the Project (the “Method Statement”),<sup>45</sup> which constitutes a part of the Subcontract,<sup>46</sup> suggests that the length of each pipe section was contemplated to be 3.0m.<sup>47</sup>

(b) A section of the bill of quantities (the “BQ”), which also forms a part of the Subcontract,<sup>48</sup> similarly suggests that the parties contemplated the pipe length to be 3.0m.<sup>49</sup> However, it should be noted that this section of the BQ is not a *priced* item, but rather a description in the BQ outside the actual list of quantities, rates and prices.

(c) Yet, in the same section of the Method Statement cited above, it is stated that “V100 Chipboard Thickness 40mm” was contemplated for use in the installation of the DN1200mm Pipeline.<sup>50</sup>

20 From these three points, it can be seen that the Subcontract is not wholly consistent. It seems that the Subcontract does expressly provide for the use of chipboard. However, the fact that it also states that pipe sections are to be 3.0m long creates a mild contradiction. The contradiction is as follows. On one hand, the Method Statement expressly provides that the parties contemplated the use of chipboard, not hydraulic joints. On the other, the evidence also shows that ICOP *knew* well before the execution of the Subcontract that the length of pipe sections would be 3.0m, and that such length would likely require the use of hydraulic joints. Indeed, Dato Cheng’s own evidence suggests that ICOP had

---

<sup>45</sup> ABOD (Vol 16) at pp 76–253 (the Method Statement).

<sup>46</sup> ABOD (Vol 16) at p 287, cl 1.1.7.

<sup>47</sup> ABOD (Vol 16) at p 131, “Pipe Diameter DN1200 (ID1200/OD1450)”.

<sup>48</sup> ABOD (Vol 16) at p 287, cl 1.1.4.

<sup>49</sup> ABOD (Vol 16) at p 294 (the BQ), “Characteristics of the Pipe jacking machine”.

<sup>50</sup> See also D&CC4 at para 14(3).

such knowledge.<sup>51</sup> Yet, as TSCE submits, despite having such knowledge, ICOP “did not bother to price the provision of hydraulic joints separately for the [DN1200mm Pipeline] because it [was] a short pipeline”.<sup>52</sup>

21 The issue to which this contradiction gives rise is whether I should take the express reference to “chipboard” in the Method Statement as obliging ICOP only to use chipboard and not hydraulic joints; or, whether I should infer from the provision of 3.0m-long pipes in the Subcontract and the surrounding context, a common intention between the parties that ICOP was obliged to use hydraulic joints due to technical constraints. After consideration, I find that this contradiction should be resolved in ICOP’s favour. In my judgment, the fact that ICOP knew about the issues which could arise from the use of 3.0m-long pipe sections – even when coupled with the fact that the Method Statement and the BQ record the pipe length as 3.0m – is not enough to conclude that the parties *agreed* by the Subcontract that ICOP would provide hydraulic joints for the DN1200mm Pipeline as part of an “all-in” rate set out in the BQ.<sup>53</sup> Put simply, I do not think there is enough evidence for me to read into S/O 2.0 of the BQ,<sup>54</sup> an agreement between TSCE and ICOP that the sum quoted therein *includes* the provision of hydraulic joints such that ICOP’s ultimate provision of such joints was not pursuant to any “variation”, but rather the terms of the Subcontract as executed in May 2017.

---

<sup>51</sup> CBAEIC (Vol 1) at pp 40–43 paras 90–96 and p 475 (Cheng Ching Keong’s AEIC).

<sup>52</sup> DCS at para 72.

<sup>53</sup> DCS at para 70; ABOD (Vol 16) at p 294 (the BQ), S/O 2.0.

<sup>54</sup> ABOD (Vol 16) at p 294.

22 I have two reasons for this view. First, ICOP’s final quotation to TSCE was issued 22 October 2016.<sup>55</sup> This predates the execution of the Subcontract *as well as* TSCE and ICOP’s pre-contractual discussions regarding the length of pipe sections for the DN1200mm Pipeline (see [20] above). The price quoted in this document for the installation of the DN1200mm Pipeline<sup>56</sup> is identical to that in the BQ.<sup>57</sup> I was not referred to any evidence showing that ICOP specifically applied its mind to whether a price adjustment was necessary in light of the fact that it would likely need to, *additionally*, supply hydraulic joints when this was not contemplated in its earlier 22 October 2016 quotation. This suggests to me that ICOP simply did not consider the point.

23 Of course, if the Subcontract clearly stipulated that ICOP was obliged to supply hydraulic joints, ICOP’s lack of consideration would not be relevant. However – and this is my second reason – the Subcontract is ambiguous. It requires me to infer this intention from contextual information and the fact that pipe lengths were to be 3.0m. This is hardly a model of contractual clarity, and when coupled with the fact that the Method Statement expressly provides that chipboard was to be used,<sup>58</sup> the ambiguity is even greater. This portion of the Method Statement has equal contractual force as the terms providing that the length of the pipes was to be 3.0m and there is no clear reason why one should be preferred over the other.

24 This brings me back then to the first question posed at [18] above. To this, I find that although the parties agreed that the DN1200mm Pipeline was to

---

<sup>55</sup> ABOD (Vol 16) at pp 268–275.

<sup>56</sup> ABOD (Vol 16) at p 269.

<sup>57</sup> ABOD (Vol 16) at p 294, S/O 2.0.

<sup>58</sup> ABOD (Vol 16) at p 131, “Pipe Diameter DN1200 (ID1200/OD1450)”.

be constructed using 3.0m-long pipe sections, there is insufficient evidence for me – upon application of the ordinary principles of contractual interpretation – to infer a specific and objective intention on both TSCE and ICOP’s parts that the price of the Subcontract upon execution was to include the cost of hydraulic joints for the DN1200mm Pipeline. There is, as such, room for ICOP’s provision of the hydraulic joints to have been the result of a variation.

25 With this finding in mind, I can turn to the second question posed at [18]. Having reviewed the evidence placed before me, I find that ICOP supplied the hydraulic joints pursuant to a variation, not of its own volition. The earliest point at which ICOP sought payment for the hydraulic joints it used in connection with the DN1200mm Pipeline was 16 May 2018.<sup>59</sup> TSCE contends that this letter has little probative value because the DN1200mm Pipeline works were completed by 14 August 2017 and ICOP made no claims at the material time. Its letter of 16 May 2018 should thus be construed as a mere “afterthought and a contrived attempt to recover more monies from TSCE”.<sup>60</sup> I do not accept this.

26 At the time of ICOP’s 16 May letter, the parties were still in a contractual relationship and although I recognise that there were some tensions – which culminated in the Subcontract being terminated in March 2019 (see [8] above) – there is nothing to suggest that ICOP was cynically reviving claims it realised it had earlier given up. Indeed, if the parties clearly understood that no such claim existed because the cost of hydraulic joints was built-into the price stated in the BQ, one naturally expects TSCE to refute the claim upon receipt of ICOP’s letter in May 2018. Yet, that is not what happened. To the contrary, in September 2018, representatives from TSCE and ICOP met to discuss various

---

<sup>59</sup> CBAEIC (Vol 1) at p 493 (Letter from ICOP to TSCE).

<sup>60</sup> DCS at paras 74–75.

problems arising in connection with the Project. The minutes of this meeting record that TSCE “agreed to pay [variation order] for additional joints by reducing the length of pipe from 3.5m to 3.0m”.<sup>61</sup> I therefore find, on a balance of probabilities, that the parties agreed to vary the Subcontract and, it was pursuant to this variation that ICOP provided hydraulic joints for its installation of the DN1200mm Pipeline. I therefore allow ICOP’s claim for the sum stated at [14] above.

### **Issue 2: Hydraulic joints for DN1600mm Pipeline**

27 This claim mostly succeeds and I award ICOP \$83,351.27 (instead of the sum of \$95,087.98 it claims in its SOC).<sup>62</sup> As with Issue 1, \$83,351.27 is the sum to which Mr Wall and Mr Snadden agree that ICOP should be entitled to recover in the event that I find in its favour.<sup>63</sup> I now briefly set out the parties’ cases and explain my decision.

28 Two items in the BQ state that TSCE was obliged to pay for the provision of “JC132 Hydraulic Joints (Pipe Length 3.5m)” and “JC238 Hydraulic Joints (Pipe Length 3.5m)”.<sup>64</sup> Relying on these entries in the BQ, ICOP avers that they were only obliged to supply the number of hydraulic joints needed to construct the DN1600mm Pipeline using 3.5m pipe sections.<sup>65</sup> Accordingly, when TSCE instructed ICOP to reduce the length of pipe sections to 3.0m, this resulted in an increase in the number of hydraulic joints needed to

---

<sup>61</sup> CBAEIC (Vol 2) at p 811 (Cheng Chin Keong’s AEIC).

<sup>62</sup> SOC at para 17 and “Claims”, number (1).

<sup>63</sup> JS(Q) at para 2.2.2.

<sup>64</sup> ABOD (Vol 16) at p 294 (the BQ), S/O 4.0 and 5.0.

<sup>65</sup> SOC at paras 12–13; PCS at paras 57, 64 and 68.

complete the installation of the pipeline.<sup>66</sup> ICOP therefore seeks to recover the additional costs it incurred.<sup>67</sup> I will return to the particulars of TSCE’s alleged instructions, and the evidence supporting such allegation, at [32] below.

29 TSCE disputes liability on three grounds. First, it asserts that ICOP was not merely obliged to supply the hydraulic joints necessary for the construction of the DN1600mm Pipeline using 3.5m pipe sections. Rather, as the Subcontract was a re-measurement contract, ICOP was simply obliged to supply the number of joints *necessary* for the total length of pipeline which it actually constructs, irrespective of the length of the pipe sections used.<sup>68</sup> Second, a different section of the BQ, which TSCE asserts is “relevant”,<sup>69</sup> shows that the length of pipe sections was contemplated to be 3.0m.<sup>70</sup> TSCE also relies on other evidence to show that ICOP was aware – prior to executing the Subcontract – that the length of pipe sections for the DN1600mm Pipeline would be 3.0m, not 3.5m. Thus, on this basis, TSCE claims there was no “variation”.<sup>71</sup> Third, and in any case, TSCE avers that it did not instruct ICOP to construct the DN1600mm Pipeline using 3.0m pipe sections; this was ICOP’s *own* decision.<sup>72</sup>

30 I do not accept TSCE’s first contention. Although the Subcontract was a re-measurement contract, that does not mean – as TSCE asserts – that the sum

---

<sup>66</sup> SOC2 at para 14.

<sup>67</sup> SOC2 at paras 15–17.

<sup>68</sup> D&CC4 at para 8.

<sup>69</sup> D&CC4 at para 9.

<sup>70</sup> ABOD (Vol 16) at p 294 (the BQ), “Characteristics of the Pipe jacking machine”.

<sup>71</sup> DCS at paras 31–43; Defendant’s Reply Submissions (18 Feb 2022) (“DRS”) at paras 32–36.

<sup>72</sup> D&CC4 at para 10.



it was liable to pay was based solely on the “length of the pipe constructed”.<sup>73</sup> The BQ set out a specific rate *per* metre for ICOP’s supply of hydraulic joints based on a pipe length of 3.5m. One logically expects this rate to increase if the length of each pipe section was shortened, and thus, more hydraulic joints are required. It is wholly unrealistic for TSCE to suggest that ICOP would have provided the exact same *per* metre quotation for hydraulic joints irrespective of the number of joints which ICOP would actually need to use in the installation of the pipeline.

31 I also do not accept TSCE’s second contention. The BQ is not consistent, but, in my view, the *priced* item (on which ICOP relies) should be preferred over the fringe description of the characteristics of the DN1600mm Pipeline on which TSCE relies. On this basis alone, I am prepared to find that the Subcontract provided for 3.5m-long pipes. However, I should add that I am mindful of the cross-examination of Dato Cheng conducted by TSCE’s counsel.<sup>74</sup> The point which counsel sought to establish during this segment of cross-examination was that ICOP was aware – prior to the execution of the Subcontract – that the length of pipe sections for the DN1600mm Pipeline would be 3.0m, not 3.5m. In my view, however, this is irrelevant. What ICOP subjectively knew or did not know is beside the point. The *priced* item in the BQ recorded that ICOP was to supply hydraulic joints at a certain rate *per* metre, and the item specifically states that the pipe length was to be 3.5m. Even if it can be said that ICOP subjectively knew that the DN1600mm Pipeline was to be built with 3.0m-long pipe sections, the BQ plainly shows that the rate *per* metre of hydraulic joints charged by ICOP was contingent on the pipe sections being 3.5m long. There is no evidence to suggest that ICOP’s knowledge caused

---

<sup>73</sup> D&CC4 at para 8(3).

<sup>74</sup> NEs (6 Oct 2021) at pp 68–75.

it to adjust the pricing in the BQ prior to executing the Subcontract. There is therefore little I can make of TSCE's cross-examination of Dato Cheng.

32 This brings me then to TSCE's third contention and whether it instructed ICOP – *after* the execution of the Subcontract – to construct the DN1600mm Pipeline using 3.0m instead of 3.5m-long pipe sections. As would be apparent from my decision (at [27] above), I find that TSCE *did* so instruct. In arriving at this conclusion, I relied on two documents. First, emails were sent by TSCE to ICOP in July 2017 (after the Subcontract was executed in May 2017) with pipe jacking drawings which showed 3.0m-long pipe sections.<sup>75</sup> Second, emails were sent by TSCE to ICOP in November 2017, with shop drawings showing, again, 3.0m-long pipe sections.<sup>76</sup> In light of my finding that the Subcontract, as executed, provided for 3.5m-long pipe sections, these emails from TSCE are sufficient to constitute an instruction capable of effecting a variation. For completeness, I should call attention to cl 4.3 of the LOA:<sup>77</sup>

In the event of any addition, omission, substitution of work set out in the BQ instructed by [TSCE], it shall constitute a variation to the Sub-Contract Works in which the valuation of such variation shall be valued based on the rates in the BQ for work of similar character and executed under similar conditions as work priced therein.

33 In my view, this clause is satisfied – either by addition or substitution – and ICOP is therefore entitled to the extra cost it incurred from having to use a greater number of hydraulic joints than provided for in the BQ. I accordingly award ICOP the sum agreed upon by Mr Wall and Mr Snadden (see [27] above).

---

<sup>75</sup> CBAEIC (Vol 1) at pp 455–458 (Cheng Ching Keong's AEIC).

<sup>76</sup> CBAEIC (Vol 12) at pp 8991–9000, 9012 (Jung Jae Hun's AEIC).

<sup>77</sup> ABOD (Vol 16) at p 289.

### Issue 3: Headwall defects in Shaft P5-2

34 This claim fails and may be disposed of briefly.

35 The thrust of ICOP’s claim is that TSCE failed to construct the headwall in Shaft P5-2 such that it was capable of withstanding 1.75 bar of pressure. On ICOP’s case, TSCE was obliged – whether by contract or tort – to ensure that the headwall could sustain this *specific* amount of pressure because the Qualified Person (Design)’s (“QPD”) prescribed such a specification.<sup>78</sup> However, the evidence given by the QPD’s assistant, David Ng (“Mr Ng”), shows that there was no such specification,<sup>79</sup> and ICOP does not contend that TSCE otherwise failed to comply with other specifications prescribed by the QPD. Thus, ICOP’s *pleaded* case, which relies solely on the alleged specification that the headwall must be able to sustain 1.75 bar of pressure, naturally fails.

36 This is enough to dismiss ICOP’s claim for \$94,821.30 comprising costs, losses and damages it incurred whilst the headwall was being rebuilt by TSCE.<sup>80</sup> It also bears highlighting at this juncture, however, that ICOP’s case includes a claim for damages suffered as a result of delays caused by TSCE (see Issue 7 at [54] below). One of the delays ICOP pleads is that which arose from TSCE’s alleged failure to construct the headwall in Shaft P5-2 in accordance with the QPD’s specifications, and TSCE’s consequent reconstruction of the headwall on ICOP’s request.<sup>81</sup> It follows from my finding above that ICOP did not have a valid legal basis to request the reconstruction of the headwall, and,

---

<sup>78</sup> SOC2 at paras 30–32.

<sup>79</sup> CBAEIC (Vol 6) at pp 3586–3588, paras 33–38 (David Ng’s AEIC).

<sup>80</sup> SOC2 at para 35.

<sup>81</sup> SOC2 at paras 33 and 61(d).

thus, it is *ICOP* which is liable for the delay caused by its request. The issue which remains is the quantification of the delay caused by *ICOP*. I will address this at [90] below when I turn to consider Issue 7.

#### **Issue 4: Defects in Shaft P5-1**

37 This claim fails.

38 At the end of Drive 2, the MTBM broke into the receiving Shaft P5-1. *ICOP* sought to extract the MTBM from the shaft but was unable to do so without dismantling the MTBM at a cost of \$104,154.54 due to a lack of working space.<sup>82</sup> The lack of working space was a consequence of a protruding pipe cap in the shaft. A photograph is most assistive to understanding the difficulty:<sup>83</sup>

---

<sup>82</sup> SOC2 at paras 26–29.

<sup>83</sup> CBAEIC (Vol 4) at p 2860 (Nicolò Alberini’s AEIC).



39 It is ICOP’s primary case that TSCE was expressly obliged by the Matrix of Responsibilities (“MOR”) to the Subcontract to construct shafts “with flushed headwall/backwall and reinforced concrete base slab *according to the project design* and microtunnelling requirement” [emphasis added].<sup>84</sup> In the case of Shaft P5-1 as the receiving shaft, various appendices to the Subcontract provided that the shaft was to be constructed with a minimum internal diameter of 7.5m “wall to wall”.<sup>85</sup> Relying on this term in the Subcontract, ICOP pleads that TSCE was obliged to construct Shaft P5-1 with 7.5m of “working space” and/or “free from any protruding objects”.<sup>86</sup> As secondary legal bases for its claim, ICOP pleads that, even if TSCE was not obliged by the express terms of

<sup>84</sup> ABOD (Vol 16) at p 264, S/O 1.15 (Matrix of Responsibilities).

<sup>85</sup> ABOD (Vol 16) at p 262 (the BQ) and p 268 (ICOP’s quotation).

<sup>86</sup> SOC2 at para 23.

the Subcontract, such a term ought to be implied,<sup>87</sup> or, in the further alternative, that such obligation should be imposed as a tortious duty of care.<sup>88</sup>

40 In support of its claim that TSCE owed and breached the above-stated obligation, ICOP makes fairly extensive submissions to tease out two seemingly significant factual points.<sup>89</sup> First, TSCE knew that the MTBM was to be extracted in one piece and that, in order to accomplish this, a certain minimum working space was required.<sup>90</sup> Second, apart from its failure to ensure that Shaft P5-1 had 7.5m of “working space” and/or was “free from any protruding objects”, ICOP submits that TSCE also failed to “properly plan the alignment of the tunnel axis” such that the point at which the MTBM broke into the receiving shaft was off-centre. More specifically, ICOP submits that TSCE failed to “account for a subterranean 400kV cable joint bay when it provided the initial tunnel alignment to ICOP” and, as a result, it was necessary for subsequent changes to be made. These changes led to the exit point in Shaft P5-1 being off-centre.<sup>91</sup> Another illustration is helpful:<sup>92</sup>

---

<sup>87</sup> SOC2 at para 23.

<sup>88</sup> SOC2 at para 24; also see PCS at para 164.

<sup>89</sup> PCS at paras 160–187.

<sup>90</sup> PCS at paras 165–166.

<sup>91</sup> PCS at paras 167–170.

<sup>92</sup> CBAEIC (Vol 4) at p 2873 (Nicolò Alberini’s AEIC).

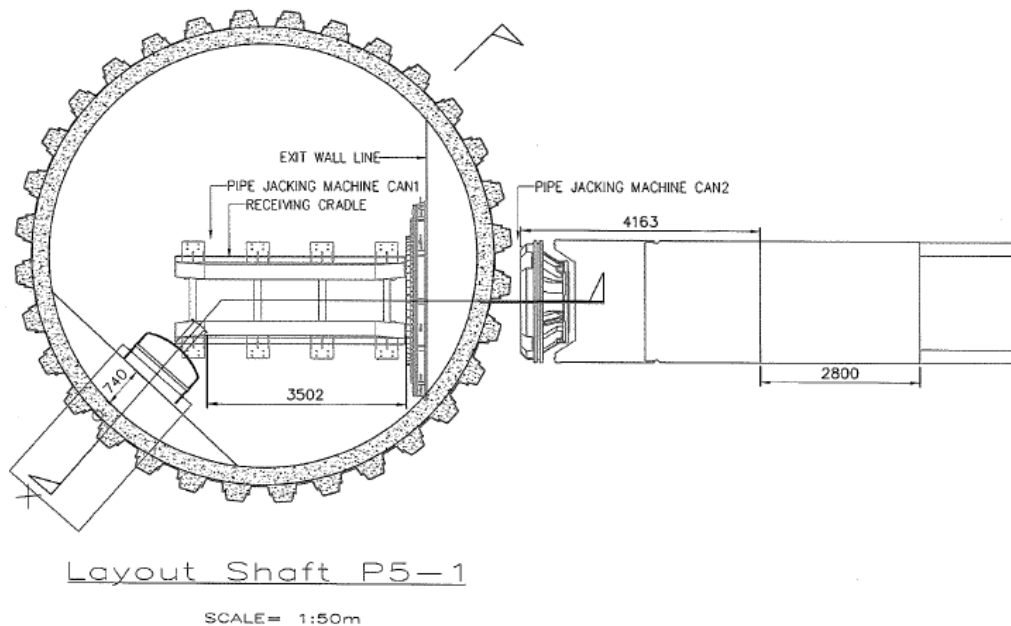

41 It can be seen from this diagram which illustrates the final alignment used in Shaft P5-1 that the exit point of the MTBM is not centred. In and of itself, this misalignment does not seem to have been problematic. However, alongside the protruding pipe cap, it was one of two features of Shaft P5-1 which collectively prevented ICOP from extracting the MTBM in one piece. As ICOP submits, “if the axis of the DN1600[mm] [Pipeline] [went] directly ... past the axis of the shaft, ... there would have been enough clearance for the MTBM to be removed *even though* the [pipe cap] was present”.<sup>93</sup> In this connection, ICOP also submits that it had brought this issue to TSCE’s attention prior to the commencement of Drive 2,<sup>94</sup> but to no avail. Ultimately, TSCE was unable to either centre the exit point of the MTBM or remove the pipe cap.<sup>95</sup>

<sup>93</sup> PCS at para 174.

<sup>94</sup> DCS at para 175.

<sup>95</sup> DCS at paras 176–185.

42 I can appreciate the predicament ICOP found itself in. However, the fact that *both* features were necessary causes of the trouble ICOP faced in extracting the MTBM poses challenges for its present claim. As TSCE correctly highlights in its reply submissions, the fact of and problems caused by the misalignment were not pleaded by ICOP.<sup>96</sup> Instead, as can be gleaned from [39] above, ICOP’s SOC was entirely focused on the presence of the protruding pipe cap. This being the case, there is, in my judgment, no room for this claim to succeed on any of the three bases pleaded by ICOP.

43 First, I reject ICOP’s attempt to interpolate the words “working space” and “free[dom] from protruding objects” into the clear terms of the Subcontract. The express words of the Subcontract simply provided that TSCE was to build Shaft P5-1 with a minimum internal diameter of 7.5m, “wall to wall”. This is a plain, clear and strict obligation which TSCE fulfilled and, if ICOP (particularly, as the microtunnelling specialist) required TSCE to adhere to more particular specifications, the onus lay on it to prescribe those specifications during the contractual negotiation and drafting process. This is not an omission properly cured by way of interpretation after the fact. Second, for the same reasons, I do not consider it appropriate to imply a term to this effect. The ordinary test for implication in *Sembcorp Marine Ltd v PPL Holdings Pte Ltd and another and another appeal* [2013] 4 SLR 193 applies, and there seems to me no gap which needs to be filled by the implication of such a specific duty. For completeness, I also note that ICOP does not make any submissions in respect of implication. It is simply asserted that such a term should be implied.<sup>97</sup>

---

<sup>96</sup> DRS at para 99.

<sup>97</sup> PCS at para 162.



44 Third – and this is where ICOP’s failure to plead the fact of the off-centre alignment is significant – I also reject ICOP’s claim that TSCE owed it a tortious duty to ensure that Shaft P5-1 had 7.5m of “working space” and/or was “free from protruding objects”. The scope of a tortious duty depends on the particular circumstances which bring the parties into proximity with each other. Here, the parties’ proximity stems primarily from the Subcontract, which does not take ICOP further than the plain terms of the contract: *Sunny Metal & Engineering Pte Ltd v Ng Khim Ming Eric* [2007] 3 SLR(R) 782 at [45]. ICOP additionally claims that TSCE *knew* that the MTBM required a minimum amount of working space, and that the presence of the pipe cap would reduce such working space (see [40] above). I am prepared to accept that the evidence bears out ICOP’s assertion. However, even if I do, that would not aid ICOP’s claim.

45 As stated at [41] above, it was *both* the presence of the pipe cap *and* the misalignment of the tunnel which resulted in the MTBM being unextractable without disassembly. This being the case, even if TSCE knew that the pipe cap would reduce ICOP’s working space, that would not be enough to hold it liable for the costs ICOP incurred to extract the MTBM. To do so, ICOP would have needed to show further that TSCE also handled the alignment issue in a way as to create sufficient proximity to give rise to the specific tortious duty pleaded.<sup>98</sup> However, given that ICOP failed to plead this matter, I decline to consider it. As such, ICOP’s tortious claim also fails on the basis that it has not established the relevant and necessary duty of care on TSCE’s part.

46 I should also emphasise that I have considered ICOP’s opposing submission that it did not need to plead the facts pertaining to the issue of

---

<sup>98</sup> SOC2 at para 24.

misalignment because: (a) these were matters of evidence; and (b) in any event, TSCE was aware of this dispute and thus not taken by surprise.<sup>99</sup> I do not accept (a). As just explained, these were material *facts* necessary and relevant to establishing proximity for the purposes of ICOP’s tortious claim. In relation to (b), my view is that in technical disputes such as this, parties ought to be bound more strictly to their pleaded cases unless they are able to provide a satisfactory explanation for their omission. Cases of this sort tend to give rise to numerous intertwined and difficult issues, and it is not for an opponent and especially not the court to piece together unpleaded points in search of the best possible case a party may advance. As observed in *V Nithia (co-administratrix of the estate of Ponnusamy Sivapakiam, deceased) v Buthmanaban s/o Vaithilingam and another* [2015] 5 SLR 1422 at [40]–[41]:

40 [T]he law permits the departure from the general rule in limited circumstances, where no prejudice is caused to the other party in the trial or where it would be clearly unjust for the court not to do so. In Singapore, the law was reiterated by this court in *OMG Holdings Pte Ltd v Pos Ad Sdn Bhd* [2012] 4 SLR 231 at [18] as follows:

... It is trite law that the court may permit an unpleaded point to be raised if no injustice or irreparable prejudice (that cannot be compensated by costs) will be occasioned to the other party (see *Lu Bang Song v Teambuild Construction Pte Ltd* [2009] SGHC 49 (*‘Lu Bang Song’*) at [17] and *Boustead Trading (1985) Sdn Bhd v Arab-Malaysian Merchant Bank Ltd* [1995] 3 MLJ 331 (*‘Boustead Trading’*) at 341–342). In the same vein, evidence given at trial can, where appropriate, overcome defects in the pleadings provided that the other party is not taken by surprise or irreparably prejudiced (see *Lu Bang Song* at [17]).

41 We should add, however, that cases where it is clear that no prejudice will be caused by the reliance on an unpleaded cause of action or issue that has not been examined at the trial are likely to be uncommon. As Rimer LJ stated in the English Court of Appeal case of *Lombard North Central plc v Automobile World (UK) Ltd* [2010] EWCA Civ 20 at [79]:

---

<sup>99</sup> Plaintiff’s Reply Submissions (18 Feb 2022) (“PRS”) at para 38.

... I am not suggesting that courts must adopt an inflexible approach to the question of whether or not a particular unpleaded issue may or may not be the subject of investigation at a trial. There will be cases in which it will be obvious that it would be unjust for the court not to entertain and decide a non-pleaded issue: for example, when it is apparent that both sides have come to court ready to deal with it as an issue in the case despite its omission from the pleadings. That, however, was not this case; and such cases are likely to be rare.

47 I emphasise from these paragraphs that the court *may* allow an unpleaded point to be pursued. It is for the court to determine whether such points should be allowed and parties do not have a right to demand such consideration. ICOP offers no explanation for its omission, and I am not convinced that TSCE would not be prejudiced by my consideration of this unpleaded point. It is for these reasons that I decline to consider the point.

48 Before leaving this issue, I should add that ICOP's failure to establish a breach on TSCE's part necessarily means that it is not entitled to an extension of time for the additional days it took to dismantle and extract the MTBM.<sup>100</sup> This logically follows, and I will address the issue of quantification at [127] below when I turn to consider the parties' delay claims under Issue 7.

#### **Issue 5: ICOP's unpaid works**

49 This claim succeeds and I award ICOP \$612,279.25.

50 From the beginning of December 2018 to the end of January 2019, ICOP carried out Drive 2 and, accordingly, issued interim progress claims ("IPCs") to TSCE.<sup>101</sup> Certain sums were claimed under these IPCs and it is in dispute

---

<sup>100</sup> CBAEIC (Vol 1) at pp 94–95, para 240 (Cheng Ching Keong's AEIC).

<sup>101</sup> SOC2 at paras 38–39 and 47–48.

whether these sums have been adequately substantiated.<sup>102</sup> However, the quantum experts – Mr Wall and Mr Snadden – have jointly assessed that ICOP has completed \$1,451,771.38 of the DN1600mm Pipeline (excluding GST).<sup>103</sup> Neither ICOP nor TSCE disputes the joint experts’ assessment, and I have not been presented with any reason to doubt the accuracy of this figure. In any event, I have also reviewed their evidence and I accept their assessment.

51 The parties agree that TSCE has previously certified and paid \$876,360 (without GST) and thus, ICOP is entitled to a balance of \$575,411.38 (also without GST) (\$1,451,771.38 – \$876,360).<sup>104</sup> However, the parties’ agreement provided for a goodwill discount, and the quantum experts have determined that the *pro rata* discount rate should be 0.554%.<sup>105</sup> ICOP’s prior IPCs do reflect deductions of goodwill,<sup>106</sup> accordingly, the discount deductible from the \$575,411.38 owing should also be pro-rated. The pro-rated goodwill discount should be  $575,411.38 \times 0.554\%$ , or \$3,187.78. Deducting this from the \$575,411.38 owing and adding 7% GST, the sum due to ICOP is \$612,279.25.

#### **Issue 6: Additional works and services**

52 It is ICOP’s case that between June 2018 and May 2019, TSCE requested that it provide various additional works and services, which it duly did. For the provision of these additional works and services, ICOP pleads that it is entitled to \$54,438.66.<sup>107</sup> In its Defence, TSCE puts ICOP to proof of its

---

<sup>102</sup> D&CC4 at paras 34 and 43.

<sup>103</sup> JS(Q) at para 2.1.

<sup>104</sup> PCS at para 111; DRS at para 358; DCS at para 593; PRS at paras 240 and 242.

<sup>105</sup> JS(Q) at para 2.1.2.

<sup>106</sup> See, *eg*, ABOD (Vol 6) at p 314.

<sup>107</sup> SOC2 at paras 54–56.

entitlement as well as quantum.<sup>108</sup> However, in view of the quantum experts' assessment,<sup>109</sup> the parties agree – in their written closings<sup>110</sup> – that ICOP is entitled to \$29,230.05 (this sum excludes GST) for this head of claim.

53 Even so, I will not at this juncture, award ICOP such sum. This is because of Mr Wall and Mr Snadden's caveat that such sum "may fall within the category of standby costs assessed for the days of critical delay". In light of this, there is a potential for double recovery and the experts suggest that such sum should not be recoverable if ICOP is also separately awarded standby costs.<sup>111</sup> ICOP accepts this,<sup>112</sup> and I will thus return to this at [138] below after determining whether ICOP is entitled to any standby costs as a result of TSCE's delay.

#### **Issue 7: The delay claim and counterclaim**

54 I turn now to the parties' delay claims. I have chosen to deal with both ICOP's claim and TSCE's counterclaim together because most of the delays which ICOP avers were caused by TSCE, TSCE opposingly asserts that ICOP is instead to be blamed.<sup>113</sup> It is therefore more convenient to assess the parties' cases based on each alleged delay. This avoids unnecessary repetition and, using this approach, there are only three additional delays alleged by TSCE in its counterclaim which need to be considered separately.<sup>114</sup>

---

<sup>108</sup> D&CC4 at paras 45–47.

<sup>109</sup> JS(Q) at para 2.2.2.

<sup>110</sup> PCS at para 189; DRS at para 364.

<sup>111</sup> JS(Q) at para 2.2.3.

<sup>112</sup> PCS at para 189.

<sup>113</sup> SOC2 at paras 61 and 64; D&CC4 at para 54.

<sup>114</sup> D&CC4 at paras 54(3), (5) and (8); PCS at paras 381–403; DRS at paras 305–322.

55 Before I turn to consider the applicable baseline programme as well as the individual delays, however, I address an unpleaded point raised by ICOP in its closing submissions.

***Preliminary: ICOP’s unpleaded claim for 259 days of delay***

56 At [11(g)] above, I stated that ICOP seeks to recover damages for a 158-day delay allegedly caused by TSCE. This is its *pleaded* case. However, in closing submissions, ICOP further claims that TSCE was responsible for another 259 days of delay prior to Drive 2. In this regard, three allegations are made. First, ICOP claims that it had to commence Drive 1 late because “TSCE changed the outer diameter of the DN1200mm Pipeline after PUB assessed that the original design would not be fit for purpose”.<sup>115</sup> Second, ICOP asserts that it “encountered an area of sticky clay” whilst performing the works for Drive 1 and, as a result, progress was slowed down. This area of sticky clay was not identified prior to the commencement of Drive 1 because “neither TSCE nor One Smart carried out the necessary soil investigation works”.<sup>116</sup> Third, ICOP claims that it was not obliged to commence Drive 2 unless and until TSCE issued a notice to proceed as required by cl 2.2 of the Subcontract read with Appendix D.<sup>117</sup> However, TSCE issued such notice late and, furthermore, the issued notice also instructed ICOP to commence works later than scheduled.<sup>118</sup>

---

<sup>115</sup> PCS at para 203.

<sup>116</sup> PCS at para 204.

<sup>117</sup> PCS at para 206; ABOD (Vol 16) at p 277, cl 2.2 (Subcontract) and p 299 (Appendix D).

<sup>118</sup> PCS at paras 206–207.

57 TSCE's primary response is that this delay was not pleaded.<sup>119</sup> Counsel for ICOP conceded as much before me during the trial<sup>120</sup> and, taking into account the same essential considerations set out at [46]–[47] above, I decline to consider these unpleaded, additional claims.

***Applicable baseline programme***

58 An applicable baseline programme is a construction programme which sets out the start and end dates of works, the planned duration of those works, and the sequence in which they are to be carried out. It serves as the schedule against which progress is tracked and also, conversely, the schedule against which delays are assessed.

59 The parties dispute the applicable baseline programme. ICOP relies on cl 2.2 of the LOA,<sup>121</sup> which provides:

The tentative scheduled Completion Date: refer Appendix D<sup>122</sup>

The parties acknowledge that the Commencement Date and Completion Date set out in Appendix D are mere tentative in nature. The actual Commencement Date and Completion Date shall subject to mutual agreement of the parties. The Main Contractor will issue a notice to proceed to you with no less than 45 days prior to the actual Commencement Date.

The parties further acknowledge that the duration set out in Appendix D is fixed on the basis that the site possession will be made available by the Main Contractor to you on a 24 hours a day basis which shall subject to the Superintending Officer's approval. In the event the site possession cannot be made available by the Main Contractor to you on a 24 hour a day basis, parties shall discuss and mutually agree on the actual Commencement Date and Completion Date.

---

<sup>119</sup> DCS at para 211.

<sup>120</sup> NEs (28 Oct 2021) at p 97 line 14 to p 99 line 1.

<sup>121</sup> ABOD (Vol 16) at p 256, cl 2.2.

<sup>122</sup> ABOD (Vol 16) at p 267.

[footnote reference to Appendix D added]

60 On 27 December 2017, ICOP wrote to TSCE to inform it that – based on the tentative schedule set out in the Subcontract (*ie*, “Appendix D”)<sup>123</sup> – the Project was, at this point, already delayed by around six months.<sup>124</sup> The next day, TSCE issued a notice to ICOP, asking that it “proceed with mobilization at shaft P5-2 from 15 January 2018 onwards”.<sup>125</sup> Based on this date of 15 January 2018 and the instructions given in the notice, ICOP then prepared a revised work programme and issued it to TSCE on 8 January 2018 (the “8 January 2018 WP”).<sup>126</sup> Subsequently, on 17 August 2018, ICOP sent a revised version of the 8 January 2018 WP which Dato Cheng suggests “took previous delays caused by TSCE into account and revised the completion dates for ICOP’s works for [Drives 2 to 4] accordingly”.<sup>127</sup> I will refer to this as the “17 August 2018 WP”.<sup>128</sup> ICOP submits that I should refer to these two work programmes “in determining ICOP’s Delay Claims”,<sup>129</sup> and suggests the amendments incorporated in the 17 August 2018 WP were “accepted by TSCE”.<sup>130</sup> To establish this, ICOP chiefly relies on a letter it sent to TSCE dated 18 August 2018 enclosing the 17 August 2018 WP; to this, TSCE responded that it had “generally no objection”.<sup>131</sup>

---

<sup>123</sup> ABOD (Vol 16) at p 267.

<sup>124</sup> ABOD (Vol 16) at p 338.

<sup>125</sup> ABOD (Vol 16) at p 340.

<sup>126</sup> ABOD (Vol 16) at pp 341–343.

<sup>127</sup> CBAEIC (Vol 1) at pp 65–66, para 158 (Cheng Ching Keong’s AEIC).

<sup>128</sup> CBAEIC (Vol 2) at pp 799–802 (Cheng Ching Keong’s AEIC).

<sup>129</sup> PCS at para 208.

<sup>130</sup> PCS at paras 212 and 284.

<sup>131</sup> PCS at para 212.



61 On the other end, TSCE submits that the applicable baseline programme was one submitted by ICOP on 25 February 2017 (before the Subcontract had been executed in May 2017) (the “25 February 2017 WP”). TSCE suggests that this should be preferred for several reasons. First, that ICOP itself took this position in a letter dated 29 March 2019.<sup>132</sup> Second, the schedule in Appendix D – which forms a part of the Subcontract<sup>133</sup> – was based on the 25 February 2017 WP.<sup>134</sup> By contrast, the 8 January 2018 WP and 17 August 2018 WP are not even compliant with Appendix D.<sup>135</sup> Third, even ICOP’s own delay expert (Mr Wall) is of the opinion that 17 August 2018 WP is inappropriate as a baseline programme because it includes as-built data and events which occurred before the commencement of pipe jacking. His view instead is that it is most appropriate to use the 8 January 2018 WP.<sup>136</sup>

62 Having considered these arguments, I am persuaded by ICOP that the 8 January 2018 WP should be the applicable baseline programme. First, I am not persuaded that the evidence demonstrates that TSCE accepted the new 17 August 2018 WP as ICOP submits.<sup>137</sup> Having “generally no objection” (see [60] above) is not enough, in my view, to amount to agreement. If the new work programme contained meaningful differences in respect of the duration of particular tasks, those differences should have been called to TSCE’s attention and agreed upon expressly. The generally passive acquiescence on which ICOP relies is equivocal at best.

---

<sup>132</sup> DCS at paras 184 and 188; CBAEIC (Vol 13) at p 9623.

<sup>133</sup> ABOD (Vol 16) at p 255, cl 1.1.6.

<sup>134</sup> DCS at para 186.

<sup>135</sup> DCS at para 187.

<sup>136</sup> CBAEIC (Vol 5) at p 3076, para 60 (George Wall’s Report on Delay Issues).

<sup>137</sup> PCS at paras 206–216; PRS at paras 83–87.

63 Second, I accept ICOP’s reliance on cl 2.2 of the LOA, and this seems to me to exclude the 25 February 2017 WP as the applicable baseline programme for two sub-reasons. One, cl 2.2 expressly records that Appendix D is tentative, which TSCE accepts.<sup>138</sup> Thus, the fact that Appendix D was based on the 25 February 2017 WP is not probative. Two, cl 2.2 also makes reference to “actual” commencement and completion dates and obliges TSCE to issue a notice to proceed “no less than 45 days prior to the *actual Commencement Date*” [emphasis added]. The timing of TSCE’s notice to proceed necessitated changes to the programme set out in the 25 February 2017 WP, and this, in my view, weakens TSCE’s position that the 25 February 2017 WP should be the applicable baseline programme. Parenthetically, I am mindful of TSCE’s submission that ICOP is renegeing on the position it took in its letter of 29 March 2019 (see [61] above). However, I am not persuaded that this is particularly significant. Given the parties’ dispute, the applicable baseline programme is a matter for the court to determine, and the fact that TSCE appears to have taken the position that the 25 February 2017 WP was the applicable baseline programme does not carry enough counterweight to the two points made above.

64 Therefore, by a process of elimination, it appears to me that the 8 January 2018 WP<sup>139</sup> is the applicable baseline programme. I will therefore consider this in rendering my decision on the issues below, and for convenience, I will append the work programme to this judgment as Annex 1. It bears noting also that, in any event, TSCE accepts that the difference between the 25 February 2017 WP and the 8 January 2018 WP is not significant.<sup>140</sup>

---

<sup>138</sup> D&CC4 at para 48.

<sup>139</sup> ABOD (Vol 16) at pp 341–343.

<sup>140</sup> DCS at paras 189–191.

Resolution of this issue was therefore more a matter of practice than necessity. With this, I turn to consider the cause of the various delays raised by the parties.

***Overview of delays in issue***

65 ICOP alleges that the following delays were caused because:

(a) TSCE failed to ensure that the worksite was in a ready-state for ICOP to mobilise and set up its equipment and deploy its personnel such that it could commence and carry out work on the various drives of the Project, without delay (the “worksite readiness and handover issue”).<sup>141</sup> In respect of this issue, ICOP claims to have suffered a 23-working day delay between 24 February and 29 March 2018, and a further 13-working day delay between 18 April and 1 August 2018.<sup>142</sup>

(b) TSCE failed to obtain the requisite approvals from the PUB and SP Powergrid Ltd (“SPPG”), which were necessary for ICOP to perform the Subcontract works in the vicinity of subterranean electricity cables and other pipelines (the “authority approvals issue”).<sup>143</sup> As a consequence of these failures, ICOP claims it suffered a 27-working day delay felt between 23 May and 25 June 2018.<sup>144</sup>

(c) TSCE failed to construct the headwall in Shaft P5-2 in accordance with the specifications in the QPD. The thrust of ICOP’s allegation in this regard has been set out at [35] above (the “headwall

---

<sup>141</sup> SOC2 at para 61(a); PCS at paras 217–243; PRS at paras 96–108.

<sup>142</sup> Plaintiff’s Further and Better Particulars (“PF&BPs”) (7 Feb 2020) at pp 30–31.

<sup>143</sup> SOC2 at para 61(c); PCS at paras 244–277; PRS at paras 109–119.

<sup>144</sup> PF&BPs (7 Feb 2020) at p 31.

issue”).<sup>145</sup> In respect of this issue, ICOP avers that it suffered 38 working days of delay, felt between 26 June and 13 August 2018.<sup>146</sup>

(d) TSCE failed to obtain permits from the National Environmental Agency (“NEA”) for ICOP to carry out the Subcontract works 20 hours per day, from Monday to Sunday. Further, despite ICOP taking steps to mitigate the noise generated by the works, TSCE’s actions did not aid but rather exacerbated the noise generated (the “noise restriction issue”).<sup>147</sup> As a consequence of not being able to work 20 hours per day, ICOP avers that it suffered 57 working days of delay, which were felt between 7 September 2018 and 14 January 2019.<sup>148</sup>

(e) TSCE failed to ensure that there was a sufficient supply of jacking pipes at the worksite which ICOP was required to install the said jacking pipes as part of its work under the Subcontract (the “insufficient pipes issue”).<sup>149</sup> ICOP does not plead the days of delay which accrued as a result of this issue.

(f) TSCE failed to ensure that the jacking pipes they supplied were of an acceptable quality in relation to the specifications set out in the Subcontract (the “poor-quality pipes issue”).<sup>150</sup> Again, ICOP does not plead the days of delay which accrued as a result of this issue.

---

<sup>145</sup> SOC2 at para 61(d); PCS at paras 278–281.

<sup>146</sup> PF&BPs (7 Feb 2020) at p 31.

<sup>147</sup> SOC2 at paras 61(f)–(g); PCS at paras 282–315; PRS at paras 151–172.

<sup>148</sup> PF&BPs (7 Feb 2020) at p 31.

<sup>149</sup> SOC2 at para 61(b)(i); PCS at paras 316–324; PRS at paras 120–130.

<sup>150</sup> SOC2 at para 61(b)(ii); PRS at paras 131–137.

(g) TSCE failed to ensure that there were adequate water treatment systems at the worksite and processes for lading, removing and transporting waste material generated from ICOP’s works away from the worksite (the “waste disposal issue”).<sup>151</sup> Again, ICOP does not plead the days of delay which accrued as a result of this issue.

(h) TSCE required ICOP to conduct an unplanned test and cutterhead inspection of the MTBM at a time when the MTBM was in the process of tunnelling from Shaft P5-2 to Shaft P5-1 (*ie*, Drive 2) at a depth of around 16 to 18m, and 230m from the closest access point at Shaft P5-2. Despite being warned that delays would result from the inspection being conducted at that time, TSCE insisted that the inspection be carried out (the “unplanned cutterhead inspection issue”).<sup>152</sup> Again, ICOP does not plead the days of delay which accrued as a result of this issue.

66 TSCE’s denies responsibility for all of the above delays and, in respect of several, it seeks to attribute them instead to ICOP. To each of these delays, TSCE responds as follows:

(a) In respect of the worksite readiness and handover issue, TSCE avers that it handed over the slurry treatment plant (“STP”) area and Shaft P5-2 to ICOP on 28 February and 2 April 2018, respectively.<sup>153</sup> However, ICOP: (i) delivered its own equipment late; (ii) had

---

<sup>151</sup> SOC2 at para 61(b)(iii); PCS at paras 325–330; PRS at paras 138–145.

<sup>152</sup> SOC2 at para 61(e); PCS at paras 331–340; PRS at paras 146–150.

<sup>153</sup> D&CC4 at para 52(1)(a).

insufficient manpower; and (iii) did not set up or install its equipment in good time. As a result of these failings, ICOP had itself caused a delay.<sup>154</sup>

(b) In respect of the authority approvals issue, TSCE admits that it was obliged to obtain the relevant approvals from the PUB and SPPG for ICOP to carry out the works in the vicinity of subterranean electricity cables and pipelines, and that such approvals were delayed.<sup>155</sup> However, it pleads that ICOP was not, in any event, in a ready state to commence works until 18 June 2018. As such, only delays following that date may be attributed to TSCE.<sup>156</sup>

(c) In respect of the headwall issue, TSCE denies liability for any delay resulting on the basis that ICOP was not entitled to request that the headwall be reconstructed in the first place. To the contrary, ICOP had itself caused delay by insisting on the reconstruction despite the fact that the QPD had approved of the original headwall design and agreed that ICOP could proceed with jacking works.<sup>157</sup>

(d) In respect of the noise restriction issue, TSCE admits that it was obliged to obtain a permit for ICOP to carry out its works on the basis of two 10-hour shifts per day. TSCE claims that TSC accordingly obtained (on behalf of TSCE) a permit from the NEA which allowed ICOP to work double shifts every day of the week. This permit prescribed the condition that the volume of the works needed to be within permissible noise limits. However, ICOP persistently caused

---

<sup>154</sup> D&CC4 at paras 52(1)(a) and 54(1)–(2).

<sup>155</sup> D&CC4 at para 52(3)(a)–(b).

<sup>156</sup> D&CC4 at para 52(3)(c).

<sup>157</sup> D&CC4 at paras 25–28, 52(4) and 54(6).

noise in excess of those limits –through no fault of TSCE – and failed to take sufficient mitigatory steps to reduce the noise generated. This resulted in the NEA prohibiting work from 10pm to 7am daily,<sup>158</sup> and ICOP is thus to blame for its own inability to work 20-hour days.<sup>159</sup>

(e) In respect of the insufficient pipes issue, TSCE admits that there were an insufficient number of jacking pipes on 2 November 2018.<sup>160</sup> However, it denies liability primarily on the basis that ICOP has not pleaded that any days of delay followed as a consequence of this issue. TSCE arrives at this submission by demonstrating that the days of delay ICOP pleads in respect of the worksite readiness and handover issue, the authority approvals issue, the headwall issue and the noise restriction issue totals 158, the total number of days of delay it claims. This thus leaves no days of delay in respect of the insufficient pipes issue.<sup>161</sup>

(f) TSCE does not specifically plead to the poor-quality pipes issue,<sup>162</sup> but denies liability on the same primary basis as the insufficient pipes issue set out immediately above.<sup>163</sup>

(g) In respect of the waste disposal issue, TSCE avers that ICOP bore the responsibility of operating the STP. On this premise, TSCE claims that any delay arising in connection with the waste disposal issue as pleaded by ICOP, arose as a result of its failure to operate the STP as

---

<sup>158</sup> PCS at para 285.

<sup>159</sup> D&CC4 at paras 52(6)–(7) and 54(7).

<sup>160</sup> D&CC4 at para 52(2)(a).

<sup>161</sup> DCS at paras 340–344.

<sup>162</sup> SOC2 at para 61(b); D&CC4 at para 52(2).

<sup>163</sup> DCS at para 362.

such.<sup>164</sup> More fundamentally, however, as with the insufficient pipes and poor-quality pipes issues, TSCE submits that ICOP did not plead that it suffered any days of delay as a result of TSCE's alleged failure to provide adequate waste disposal facilities.<sup>165</sup>

(h) In respect of the unplanned cutterhead inspection issue, TSCE's case is that it was entitled under the Subcontract to request inspections to ensure the safety of the Subcontract works.<sup>166</sup> TSCE also mounts several factual defences,<sup>167</sup> but as with the insufficient pipes, poor-quality pipes and waste disposal issue, it also submits that ICOP is not entitled to any claim for delay because it has not pleaded that it suffered any days of delay in connection with this issue.<sup>168</sup>

67 TSCE *also* avers that, in addition to the above, ICOP delayed the progress of the Subcontract works by the following:

(a) ICOP carried out the pipe jacking works at a slow rate (the "slow pipe jacking issue").<sup>169</sup>

(b) ICOP demobilised its equipment from the worksite at a slow rate (the "slow demobilisation issue").<sup>170</sup>

---

<sup>164</sup> D&CC4 at paras 52(2)(c)–(d).

<sup>165</sup> DCS at para 369.

<sup>166</sup> D&CC4 at paras 52(5)(a)–(b).

<sup>167</sup> D&CC4 at para 52(5)(c).

<sup>168</sup> DCS at para 380.

<sup>169</sup> D&CC4 at para 54(3).

<sup>170</sup> D&CC4 at para 54(5).



(c) ICOP removed the MTBM from the worksite around 28 January 2019 after Drive 2 (the “removal of the MTBM issue”).<sup>171</sup>

***The worksite readiness and handover issue***

68 Preliminarily, I am mindful of certain inconsistencies between the dates of delay set out in ICOP’s pleaded case, and those set out in the affidavit of evidence-in-chief (“AEIC”) of Dato Cheng. These inconsistencies were also highlighted by TSCE in its written closing submissions.<sup>172</sup> This lack of precision is unfortunate but not ultimately significant because the simple starting point is to ask what task, during this period, was on the critical path.

69 The parties’ delay experts, Mr Wall for ICOP and Samuel Widdowson (“Mr Widdowson”) for TSCE, broadly agree that the completion of Shaft P5-2 and its handover to ICOP were one of two possible tasks on the critical path; they also agree that the date on which TSCE was obliged to handover Shaft P5-2 was 24 February 2018.<sup>173</sup> The other potential task driving the critical path was ICOP’s mobilisation of its equipment to the worksite, which was supposed to commence on 28 February 2018. Mr Widdowson makes it a point to clarify that it is not possible to establish the true driving critical path “due to a lack of evidence relat[ing] to the actual progress of ICOP’s [e]quipment [m]obilisation”.<sup>174</sup>

70 From [65(a)] and [66(a)] above, it can be seen that ICOP and TSCE have essentially capitalised on the equivocal nature of the experts’ opinion to advance

---

<sup>171</sup> D&CC4 at para 54(8).

<sup>172</sup> DCS at paras 225–226.

<sup>173</sup> NEs (27 Oct 2021) at p 25 line 12 to p 28 line 18; Joint Statement (Delay) (7 Jul 2021) (“JSD”), Appendix JS-A (“Scott Schedule”) at S/N 1.1.3.

<sup>174</sup> Scott Schedule at S/N 1.1.3.

the case most advantageous to each of them. I begin with ICOP’s case. As a starting point, there is no dispute that TSCE only handed over Shaft P5-2 on 2 April 2018,<sup>175</sup> and this was a delay from the expected handover of 24 February 2018. Thus, relying on this, ICOP avers that the *critical* delay was caused by TSCE’s failure to hand over the worksite. Indeed, ICOP goes further and claims in its closing submissions that it was only given “unfettered access” to Shaft P5-2 on 6 April 2018.<sup>176</sup> I digress momentarily to deal with this argument.

71 On Dato Cheng’s account, ICOP was *allowed* to set up its equipment in Shaft P5-2 from 28 March 2018, but it was unable to do so because TSCE was still carrying out works in the shaft. For example, TSCE was rectifying defects within the shaft to address water leakages on 3 April 2018. Thus, he testifies, ICOP could only proceed to carry out works in Shaft P5-2 – the installation of the rubber ring seal on the headwall – on 4 April 2018. Even then, he claims that TSCE had left behind detritus in the shaft, and so ICOP had to spend the rest of 4 April 2018 clearing it so as to prepare it for the installation of other necessary equipment.<sup>177</sup> The daily site reports exhibited by Dato Cheng in his affidavit of evidence-in-chief (“AEIC”) seem to support his account, but only to the extent that TSCE continued to carry out works on 3 April 2018.<sup>178</sup> “Housekeeping” is recorded as having been done on 4 April 2018, but it is unclear to me whether this amounted to a full day of clearing out detritus as Dato Cheng suggests.<sup>179</sup> In general, there is some ambiguity as to how ICOP

---

<sup>175</sup> JSD at p “JS1 - 2/12”; also see D&CC4 at para 52(1)(a).

<sup>176</sup> PCS at paras 226.

<sup>177</sup> CBAEIC (Vol 1) at p 54, paras 124–125 (Cheng Ching Keong’s AEIC).

<sup>178</sup> CBAEIC (Vol 1) at pp 593–595 (Cheng Ching Keong’s AEIC).

<sup>179</sup> CBAEIC (Vol 1) at pp 596–598 (Cheng Ching Keong’s AEIC); also see DCS at paras 271–272.

arrived at the submission<sup>180</sup> that it had only been given unfettered access of Shaft P5-2 on 6 April 2018.

72 I am therefore not satisfied that Shaft P5-2 was only handed over to ICOP on 6 April 2018. I am also not satisfied that the shaft was only properly handed over to ICOP on 4 April 2018, notwithstanding that the daily site report for 3 April 2018 records, “shaft inside water leaking location patch up & base slab loose conc hacking”.<sup>181</sup> Under the MOR, TSCE was responsible for:<sup>182</sup>

1.14 Construction project of shafts, draw up of safety documentation included

1.15 Construction of shafts with flushed headwall/backwall and reinforced concrete base slab according to the project designs and microtunnelling requirement

1.17 Dewatering of water from Shaft (If leaking from shaft)

73 However, even if TSCE had been responsible for carrying out works in the shaft between 3 to 6 April 2018, the mere allocation of these responsibilities to TSCE does not necessarily prove a further delay in its handover of the shaft to ICOP. I further note that in an earlier amendment of ICOP’s Reply and Defence to Counterclaim, ICOP pleaded that TSCE handed over Shaft P5-2 on 2 April 2018.<sup>183</sup> This pleading was subsequently removed from its Reply and Counterclaim, but ICOP has not pleaded any other handover date in its place.<sup>184</sup> Given the lack of clarity in ICOP’s pleaded position and ambiguity in its

---

<sup>180</sup> PCS at para 226.

<sup>181</sup> CBAEIC (Vol 1) at p 594 (Cheng Ching Keong’s AEIC).

<sup>182</sup> ABOD (Vol 16) at pp 263–264, S/O 1.14, 1.15 and 1.17 (Matrix of Responsibilities).

<sup>183</sup> Reply and Defence to Counterclaim (Amendment No 1) (7 Oct 2020) (“R&DC1”) at para 33.

<sup>184</sup> Reply and Defence to Counterclaim (Amendment No 2) (4 August 2021) (“R&DC2”) at para 33.

submissions as to when Shaft P5-2 was handed over, I am unable to accept its submission that the handover date was 6 April 2018.

74 Having established that TSCE handed over Shaft P5-2 on 2 April 2018, I turn to TSCE’s opposing case. In essence, TSCE claims that, even after the worksite was handed over, ICOP was still unable to mobilise its equipment in accordance with the timelines stipulated in the applicable baseline programme.<sup>185</sup> As stated at [66(a)] above, it is TSCE’s case that the STP area and Shaft P5-2 were handed over to ICOP by 28 February and 2 April 2018 respectively. However, ICOP caused several delays on its own part. First, ICOP was not ready to start assembly of the STP upon the STP area being handed over, and no such work was carried out between 6 March and 6 August 2018 due to late deliveries of ICOP’s equipment and materials, as well as a shortage of manpower.<sup>186</sup> Second, ICOP was supposed to mobilise its equipment by 16 March 2018,<sup>187</sup> but it failed to do so on account of late deliveries of equipment. Specifically, TSCE avers that the primary generator and MTBM only arrived on site on 27 April 2018.<sup>188</sup> Third, ICOP was supposed to commission and test all of its equipment onsite (including the MTBM) by 5 April 2018,<sup>189</sup> and pipe jacking was to commence on 7 April 2018.<sup>190</sup> However, ICOP only commissioned and tested its equipment on 16 and 17 May 2018, and pipe jacking “only commenced on 22 May 2018”.<sup>191</sup> In respect of TSCE’s pleading

---

<sup>185</sup> Annex 1: Applicable Baseline Programme, WorkCode 1.1.2.1.1.3 to 1.1.2.1.1.6.

<sup>186</sup> D&CC4 at paras 52(1)(a) and 54(1)(b).

<sup>187</sup> Annex 1: Applicable Baseline Programme, WorkCode 1.1.2.1.1.3.

<sup>188</sup> D&CC4 at para 54(1)(a).

<sup>189</sup> Annex 1: Applicable Baseline Programme, WorkCode 1.1.2.1.1.8.

<sup>190</sup> Annex 1: Applicable Baseline Programme, WorkCode 1.1.2.1.1.10.

<sup>191</sup> D&CC4 at para 54(2).

that pipe jacking *commenced* on 22 May 2018, I believe there is an error. I will deal with this in the next section, at [79] below.

75 In response to TSCE's first allegation, ICOP responds that its equipment, vehicles and personnel (amongst other things) remained in the relevant areas of the worksite after the handover, such that it was unable to commence work without delay or difficulty.<sup>192</sup> In response to the second, ICOP admits that the primary generator and the MTBM only arrived on the worksite on 27 April 2018. However, it avers that there was no reason to mobilise these items to the worksite earlier as TSCE only completed levelling the worksite on 26 April 2018.<sup>193</sup> In response to the third, ICOP avers that the delays in respect of the commissioning and testing of its equipment, and the commencement of the pipe jacking works was a consequence of the prior delays caused by TSCE.<sup>194</sup>

76 Having considered these back-and-forth allegations, my view is that the parties and the experts have missed the wood for the trees. The critical delay was not caused by TSCE's late handover of the worksite, nor was it caused by ICOP's allegedly delayed mobilisation of equipment to the worksite even after it had been handed over. As I will explain in the next section in resolution of the authority approvals issue, irrespective of how promptly TSCE handed over the worksite and ICOP mobilised its equipment, ICOP simply could not commence pipe jacking works until the necessary approvals had been obtained by TSCE from SPPG and the PUB. Such approvals were only obtained *after* ICOP was ready to commence pipe jacking works.

---

<sup>192</sup> R&DC2 at para 32.

<sup>193</sup> R&DC2 at para 45.

<sup>194</sup> R&DC2 at para 46.

***The authority approvals issue***

77 Three crucial matters were accepted by Mr Jung Jae Hun (“Mr Jung”), a project manager for TSCE, at trial:

- (a) First, until approval was obtained from SPPG and the PUB, ICOP could *not* commence pipe jacking works.<sup>195</sup>
- (b) Second, SPPG only provided its approval on 20 June 2018 and the PUB, its approval, on 25 June 2018.<sup>196</sup>
- (c) Third, TSCE had aimed to obtain these approvals from SPPG and the PUB by 4 April 2018.<sup>197</sup>

78 I should add that this third point is consistent with the applicable baseline programme, which scheduled the MTBM for launch on 6 April 2018, with pipe jacking works for Drive 2 to be carried out across 66 days from 7 April 2018 to 22 June 2018.<sup>198</sup>

79 These three points having been accepted by TSCE’s Mr Jung, it seems to me clear that so long as ICOP was ready to commence pipe jacking works *before 25 June 2018*, it was TSCE’s failure to obtain SPPG and the PUB’s approvals which caused the *critical* delays. TSCE makes extensive submissions to the end of showing that ICOP was, until 18 June 2018, itself unable to commence pipe jacking works.<sup>199</sup> First of all, I do not accept this as a matter of

---

<sup>195</sup> NEs (28 Jul 2021) at p 27 lines 13–22.

<sup>196</sup> NEs (28 Jul 2021) at p 27 lines 2–12.

<sup>197</sup> NEs (28 Jul 2021) at p 36 lines 3–12.

<sup>198</sup> Annex 1: Applicable Baseline Programme, WorkCode 1.1.2.1.1.10.

<sup>199</sup> DCS at paras 301–331.

fact. There is clear correspondence stemming *from TSCE* which suggests that, on 21 May 2018, ICOP was ready to commence pipe jacking subject to the requisite approvals being obtained from SPPG and the PUB.<sup>200</sup> Second, as I mentioned at [74] above, I believe there is an error in TSCE’s pleaded case that pipe jacking works for Drive 2 *commenced* on 22 May 2018. Works could not have commenced on this date given that, as I have just stated, the approvals from SPPG and the PUB had not yet been obtained. Therefore, it appears that what TSCE *meant to plead* was that ICOP was ready to commence pipe jacking works on 22 May 2018. This is consistent with the correspondence showing that ICOP was ready to commence pipe jacking works on 21 May 2018.

80 I am mindful that TSCE does also plead elsewhere in its Defence and Counterclaim that ICOP was only ready to start works on 18 June 2018.<sup>201</sup> The lack of consistency is unfortunate but ultimately, again, inconsequential. This is because, even if I accepted *all* of TSCE’s factual arguments and found that ICOP was *also* not ready until 18 June 2018, that would not – in any event – be sufficient for TSCE to avoid liability. In my view, TSCE’s failure to obtain the requisite approvals from SPPG and the PUB should properly be seen as *the cause* of the delay. And, even if ICOP was itself not ready before 18 June 2018 to commence pipe jacking works, that should not absolve TSCE of liability for the *full* delay until 25 June 2018. I will explain.

81 In cases involving two potential causes of a delay, the usual approach is to ask which of the causes was the “but for” cause. This is trite law, but it is equally trite that causal arguments are notoriously fluid and can be formulated in a variety of different ways, to reach opposite conclusions, some less and some

---

<sup>200</sup> ABOD (Vol 22) at pp 38–41.

<sup>201</sup> D&CC4 at para 52(3)(c).

more logical. In the present case, TSCE argues that, because ICOP was not ready until 18 June 2018, it is *equally responsible* for the delay until this date.<sup>202</sup> I do not accept this. To be clear, this is not to say that I am rejecting the application of the well-established and simple “but for” view of causation. I accept that, if one views the facts through the lens of the hypothetical alternative reality which favours TSCE – that is, one in which TSCE managed to obtain the approvals from SPPG and the PUB on time – TSCE’s argument that neither party solely caused the delay of the Subcontract works would be vindicated. However, I find that, in the present case, the causal inquiry is not helpfully answered through the use of alternative hypothetical realities. Moreover, this form of causal reasoning tends only to be necessary in cases where we wish to probe the effect of a particular failure. Typically, this is necessary when such effect is either unknown or unclear. For example, where a contractor contends that an employer’s lesser delay caused the contractor’s own greater delay. In such cases, we would need to determine if, and the extent to which the employer’s delay bore on the contractor’s progress. Only after this has been determined, can the court reach a conclusion as to who is responsible for the critical, greater, delay.

82 This is not the case here. Given Mr Jung’s concession (see [77(a)] above), we *know* clearly for a fact that pipe jacking works simply could not commence until 25 June 2018. It is thus not the proper subject of inquiry to ask what would have happened had TSCE managed to obtain the approvals from SPPG and the PUB by 4 April 2018, as planned. Instead, for the purposes of the present case, we are seeking to uncover the “but for” reason why pipe jacking works could only commence after 25 June 2018. The answer to this is simply TSCE’s failure to obtain the requisite approvals. Whether or not TSCE handed

---

<sup>202</sup> DCS at para 331.



over the worksite on time and in a ready-state, and whether or not ICOP was timely in mobilising its equipment to the worksite is causally irrelevant.

83 I therefore find, in respect of the worksite readiness and handover issue as well as the authority approvals issue, that TSCE was the cause of the critical delay. I note that, in respect of the worksite readiness and handover issue, neither Mr Wall nor Mr Widdowson has opined that the critical path is TSCE's failure to obtain the relevant approvals from SPPG and the PUB.<sup>203</sup> However, I depart from their view. In my judgment, the critical path in respect of both these issues was the same – TSCE's obtainment of the requisite approvals needed for works to be commenced – and I prefer this view because both issues concern whether ICOP *could even* commence works. This is to be distinguished from the headwall issue which I considered at [34]–[36] above and round off at [90] below, which concerns ICOP's judgment in respect of whether works *ought to be* commenced in the face of what it considered subpar pressure testing results. It may also be distinguished from the noise restriction issue which I consider at [95]–[104] below, which concerns ICOP's ability to *carry on, and therefore, complete* the works in a timeous manner.

84 The import of my analysis, however, is that any delays caused by either TSCE or ICOP in respect of the period before ICOP was scheduled to launch the MTBM and commence pipe jacking works (*ie*, 6 April 2018: see [78] above) were not critical delays. They were non-critical delays for which neither party should be held responsible. This is because the task on the critical path – as I have determined – was TSCE's obligation to obtain the requisite approvals from SPPG and the PUB, and this was a delay to ICOP's *commencement* of the pipe jacking works. Therefore, the delay for which I find TSCE is liable is *only* from

---

<sup>203</sup> Scott Schedule at S/N 1.1.3.

6 April to 25 June 2018. Any alleged delay resulting from the worksite readiness and handover issue prior to 6 April 2018 is, on this analysis, merely by the by, and need not be determined.

85 As to the number of days of delay for which TSCE is liable, there is a mild difficulty in arriving at a figure. Neither Mr Wall nor Mr Widdowson have conducted their delay analyses cleanly for the period of 6 April to 25 June 2018 as I have found is appropriate. Indeed, neither of them undertook their analyses of the delay for this period on the basis that the task driving the critical path – as regards *both* the worksite readiness and handover issue, as well as the authority approvals issue – was TSCE’s attainment of SPPG and the PUB’s approvals for pipe jacking works to commence. That said, this issue is easily resolved. The number of days of critical delay attributable to TSCE, on my analysis, would simply be the number of calendar days in this period not including Sundays, *ie*, 69 days. This is because: (a) the Subcontract only provided for a six-day work week;<sup>204</sup> and (b) having determined the driving critical path as I have, there is no need to account for other occurrences between 6 April and 25 June 2018 which may reduce the number of days of critical delay attributable to TSCE. Each of the available working days during this period may be taken as wholly lost as a result of the authority approvals issue.

86 The primary remedy which ICOP seeks in respect of its various delay claims is damages representing the standby costs it incurred as a result of those delays.<sup>205</sup> The parties’ experts on quantum, Mr Wall and Mr Snadden, have agreed on the daily standby cost rates to be applied in respect of ICOP’s delay claim. The rates differ from month to month. For April 2018, they agree that the

---

<sup>204</sup> ABOD (Vol 16) at p 269 read with p 287, cl 1.1.8.

<sup>205</sup> SOC2 at “Claims”, number (8).

rate to be applied is \$3,414.28; for May 2018, the rate is \$6,906.22; and for June 2018, the rate is \$6,817.65.<sup>206</sup> Of the 69 days of critical delay I have determined to be attributable to TSCE, 21 fell within April 2018, 27 fell within May 2018, and 21 fell within June 2018. The standby costs which ICOP is entitled to recover for this period, therefore, is  $(21 \times 3,414.28) + (27 \times 6,906.22) + (21 \times 6,817.65)$ , which amounts to \$401,338.47.

87 Next is the cost of rental ICOP incurred in leasing the MTBM from its related company in Malaysia, ICOP Construction (M) Sdn Bhd. Such rental is not included in the daily standby cost figures above and needs to be considered separately. Mr Wall and Mr Snadden generally agree that the daily rate for the MTBM (as well as its connected control container) is \$9,120.<sup>207</sup> However, they disagree as to the extent of ICOP's entitlement to recover such sum in respect of critical delays caused by TSCE. Mr Wall's view is that the rate is applicable to all days of critical delay determined to have been caused by TSCE. That is, if I apply his view, ICOP would – on top of the \$401,338.47 I awarded it in standby costs – be entitled to a further sum of  $69 \times 9,120$ , *ie*, \$629,280 in respect of the 69-day delay from 6 April to 25 June 2018. Mr Snadden points to a clause in the lease agreement for the MTBM<sup>208</sup> which provides that, even if ICOP terminated the lease agreement, it was minimally obliged to pay the lease for the MTBM for a period of 18 months.<sup>209</sup> Thus, Mr Snadden suggests that ICOP should only be entitled to recover the rental of the MTBM if TSCE causes a critical delay beyond this minimum 18-month lease period. By his

---

<sup>206</sup> JS(Q) at para 2.3.7.

<sup>207</sup> JS(Q) at para 3.2.2(a) and (b).

<sup>208</sup> ABOD (Vol 4) at pp 242–246.

<sup>209</sup> ABOD (Vol 4) at p 242, cl 3.4.

calculations,<sup>210</sup> based on the planned duration of the Subcontract works, TSCE could cause up to 179 days of critical delay which would not have any impact of ICOP’s minimum obligation to pay rent for the MTBM. It is only *past* these 179 days, that ICOP would begin to suffer losses.

88 I prefer Mr Snadden’s evidence and accept his calculations. Having undertaken a minimum 18-month obligation to pay rent on the MTBM, ICOP cannot contend that it suffered any remediable losses *unless* it can establish that the delays TSCE caused it to incur costs beyond the payments it would have had to make in any event. To be clear, this is not to say that ICOP does not have a remedy in respect of the rental costs it incurred by undertaking this 18-month obligation at all. If it can be shown that TSCE breached the Subcontract, that such breach was repudiatory, and that ICOP therefore rightfully terminated the Subcontract (an issue to which I will turn at [143] below), it can be argued that ICOP should be entitled to recover at least some of such rental falling within this minimum 18-month period. The argument – from ICOP’s perspective – would be that, had TSCE not committed a repudiatory breach, ICOP would have been able to complete the Subcontract works and earn its contract fees to offset the cost of renting the MTBM. However, this is not an argument which can be made on a *delay* claim. I therefore do not award ICOP any sum in respect of the rental costs it incurred for the MTBM.

89 For completeness, I should also state that I am mindful of cl 4.4 of the LOA.<sup>211</sup> This clause provides that ICOP is entitled to \$8,250 “per working shift” for “Idle Time on site due to reasons not attributable” to ICOP. This figure seems to concern all time-related costs, *including* the cost of renting the MTBM.

---

<sup>210</sup> Joint Presentation (Quantum) (19 Oct 2021) at slides 13–14.

<sup>211</sup> ABOD (Vol 16) at p 289.

Accordingly, if this rate is applied, ICOP would be compensated for delays at a rate substantially lower than its actual standby costs *and* the cost of renting the MTBM. On this issue, Mr Snadden observes that, it is “highly questionable, from a commercial perspective, that [ICOP] would knowingly agree with [TSCE] a subcontract rate that is significantly lower than a purported cost base”.<sup>212</sup> In my judgment, in so far as the present dispute is concerned, there is no need to peer behind the parties’ bargain – as Mr Snadden’s remark suggest is necessary – to determine the significance of this figure. ICOP has not relied on this in its claim for damages and has instead sought to prove its actual losses.<sup>213</sup> There is also no suggestion from TSCE that ICOP is bound by this figure and may not, as it has done, seek to prove the losses it actually incurred by way of standby costs. In any case, it seems to me that the Subcontract contemplated two working shifts per working day,<sup>214</sup> such that the sum of \$8,250 “per working shift” was not commercially illogical. Clause 4.4 of the LOA therefore does not affect my findings on quantum above.

### ***The headwall issue***

90 I have found at [36] above that ICOP is liable for the delay caused by its request that TSCE reconstruct the headwall in Shaft P5-2. The outstanding issue which requires consideration is the extent of the delay caused by ICOP for the purposes of TSCE’s counterclaim.<sup>215</sup> For TSCE, Mr Widdowson assesses that the actual critical delay resulting from the headwall issue was 50 calendar days; the assessment period being 26 June 2018 until 14 August 2018. Mr Wall’s

---

<sup>212</sup> JS(Q) at para 3.2.2(c)(iv).

<sup>213</sup> SOC2 at “Claims”, number (8).

<sup>214</sup> ABOD (Vol 16) at p 301 at para 4.1(p) (read with ABOD (Vol 16) at p 287, cl 1.1.8).

<sup>215</sup> D&CC4 at paras 54(6) and 65–68.

assesses that the actual critical delay attributable to the headwall issue is 59 calendar days for the period between 27 June 2018 and 24 August 2018.<sup>216</sup>

91 I prefer Mr Widdowson’s analysis for one general reason, though I will make one minor adjustment. I do not agree with the dates selected for Mr Wall’s analysis. In respect of the commencement date, Mr Wall commences his analysis on 27 June 2018 on the basis that this was the date on which “ICOP decided that it could not progress with the works”. By contrast, Mr Widdowson prefers 26 June 2018 because this is the date that ICOP was advised that it could commence the launch of the MTBM.<sup>217</sup> Following from my analysis of the worksite readiness and handover issue as well as the authority approvals issue, the latter view is evidently more sound. Once the requisite approvals from SPPG and the PUB were obtained by TSCE on 25 June 2018, ICOP could commence the next stage of works on the very next day. Indeed, this is ICOP’s own pleaded case.<sup>218</sup> In respect of the date on which this delaying event ended, Mr Wall selects 24 August 2018 because this is after the “successful completion of the water seal test on 23 August 2018, enabling ICOP [to] be back in the same position that it had been previously”.<sup>219</sup> This, again, is not consistent with ICOP’s pleaded case that the delay persisted until 13 August 2018.<sup>220</sup> I therefore do not accept that any delay past 13 August 2018 should be determined.

92 In the same vein, however, I reduce Mr Widdowson’s assessment of 50 days by one day to account for the fact that his analysis includes 14 August

---

<sup>216</sup> Scott Schedule at S/N 1.3 (“Construction of Headwall”).

<sup>217</sup> Scott Schedule at S/N 1.3.1.

<sup>218</sup> PF&BPs (7 Feb 2020) at p 31, answer (i)(a)(iii).

<sup>219</sup> Scott Schedule at S/N 1.3.1.

<sup>220</sup> PF&BPs (7 Feb 2020) at p 31, answer (i)(a)(iii).

2018. TSCE also does not plead that ICOP was, by the headwall issue, responsible for delays on or after 14 August 2018. To the contrary, in its written closing, TSCE submits that “as ICOP has only pleaded that the delays resulting from the [headwall issue] operated up till 13 August 2018, any delays occurring from 14 August 2018 to 24 August 2018 do not form a part of ICOP’s pleaded case and must not be considered in these proceedings”.<sup>221</sup> I accept this and find that ICOP is liable, in respect of the headwall issue, for 49 days of actual critical delay.

93 In any event, I should also add that, since the extent of this delay concerns TSCE’s counterclaim, given that I have accepted the position of TSCE’s own expert witness, which advances a lower figure than ICOP’s expert witness, there should be no quarrel about the approach taken.

94 On the issue of quantum, the primary remedy TSCE seeks is liquidated damages.<sup>222</sup> For this, it relies on cl 2.3 of the LOA which provides that liquidated damages are to be calculated at a rate of “0.03% of the [Subcontract] Sum per calendar day, subject to a maximum limit of 50% of the [Subcontract] Sum”.<sup>223</sup> On the joint calculations of Mr Wall and Mr Snadden, this amounts to \$1,710 per day subject to a cap of \$2,850,000.<sup>224</sup> I therefore award TSCE liquidated damages of  $49 \times 1,710$ , *ie*, \$83,790, in respect of the headwall issue.

---

<sup>221</sup> DCS at para 335.

<sup>222</sup> D&CC4 at paras 66 and “Claims”, number (1).

<sup>223</sup> ABOD (Vol 16) at p 288.

<sup>224</sup> JS(Q) at para 4.2.2.

***The noise restrictions issue***

95 I do not allow ICOP’s delay claim in respect of the noise restriction issue. Submissions in respect of this issue are quite lengthy and detailed,<sup>225</sup> however, my reasoning in resolution of this issue is straightforward and can be stated in three relatively simple steps.

96 First of all, ICOP does not dispute that TSCE managed to obtain a work permit from the NEA which allowed ICOP to carry out its pipe jacking works throughout the night.<sup>226</sup> However, the noise generated primarily by the 1100KV power generator persistently exceeded the noise limit imposed by the NEA’s permit.<sup>227</sup> To address this, on 4 September 2018, TSCE sent a letter to ICOP highlighting the noise and asking that it propose mitigation measures.<sup>228</sup> Shortly thereafter, on 11 September 2018, the NEA issued a warning to TSCE cautioning them that if the applicable noise limits continued to be exceeded, the NEA “would not hesitate to issue a notice to restrict the working hours of the construction site”.<sup>229</sup> TSCE forwarded this letter along with a noise mitigation plan on the same day.<sup>230</sup>

97 Still on the same day, TSCE met with the NEA which prescribed some noise mitigation measures and prohibited pipe jacking works from 10pm to 7am nightly, until the mitigation measures had been put in place and NEA was

---

<sup>225</sup> PCS at paras 282–315; DRS at paras 268–304; DCS at paras 388–496; PRS at paras 151–172.

<sup>226</sup> PCS at para 285; DCS at para 391; ABOD (Vol 4) at p 401.

<sup>227</sup> CBAEIC (Vol 12) at pp 8831–8832, para 235 (Jung Jae Hun’s AEIC).

<sup>228</sup> CBAEIC (Vol 17) at p 12073 (Jung Jae Hun’s AEIC).

<sup>229</sup> ABOD (Vol 4) at p 410.

<sup>230</sup> CBAEIC (Vol 17) at p 12077 (Jung Jae Hun’s AEIC).



convinced that noise limits would not continue to be exceeded.<sup>231</sup> ICOP refers to this as the “Stop Work Order”.<sup>232</sup> For accuracy, I should note that this Stop Work Order is only captured in an email from TSCE setting out the discussion at such meeting. The parties did not refer me to an official notice or order from the NEA revoking the all-day work permit earlier granted. In any case, there is no dispute that such a Stop Work Order had been made and persisted throughout Drive 2,<sup>233</sup> so the lack of clearer documentation does not affect my decision.

98 Second, cl 4.8.5 of the LOA provided:<sup>234</sup>

**4. [Subcontract] Sum**

...

4.8 You acknowledge that you have, in agreeing to the [Subcontract] Completion Date and the [Subcontract] Sum, taken account of all necessary matters and things, including but not limited to the following:

...

4.8.5 all requirements for plant and equipment to be available for operation 24 hours a day for the duration of the [Subcontract] Works, subject to permission being obtained from the Main Contractor and, where required, the relevant authorities.

“You” in this clause refers to ICOP.

99 In my judgment, this clause squarely placed the obligation on ICOP to ensure that noise restrictions are complied with so that pipe jacking works can be carried out throughout the day. ICOP attempts to resist this conclusion by arguing that this clause has “nothing to do” with noise constraints or work

---

<sup>231</sup> CBAEIC (Vol 17) at p 12083 (Jung Jae Hun’s AEIC).

<sup>232</sup> PCS at para 285.

<sup>233</sup> PCS at para 285; DCS at para 516.

<sup>234</sup> ABOD (Vol 16) at pp 278–279.

permits. But, rather, the clause simply requires ICOP’s plant and equipment to be “mechanically” available for operation 24 hours a day.<sup>235</sup> I do not accept this interpretation. The language of the clause is broadly cast and, objectively, seems to have in mind the goal of timely completion. This is evident from the phrases “in agreeing to the [Subcontract] Completion Date” and “available for operation”. These clearly envisioned that ICOP’s plant and equipment would be generally available for use to the end of meeting the completion date. There would be little utility in ICOP ensuring its equipment could, mechanically, be used, when legally, they were prohibited from doing so.

100 Third, given that ICOP bore the obligation of complying with noise limits prescribed by the NEA, there are – to my mind – only two relevant ways in which ICOP can argue that TSCE should nevertheless be held liable for the delay flowing directly from the breach of such noise limits. First, ICOP may contend that TSCE acted in a manner which prevented it from staying within those noise limits. Second, ICOP may contend that TSCE did not give it notice that the NEA had taken issue with the breaches of the noise limits such that, if mitigatory measures were not taken, the Stop Work Order would be issued. In other words, TSCE did not give ICOP a fair chance to take mitigatory steps.

101 The shape of the parties’ dispute in their written submissions seem to engage – at least to some extent – these two bases for holding TSCE liable for the delay. However, these are not the bases of ICOP’s pleaded case. ICOP’s case is that “TSCE had failed to obtain permits from the relevant authorities to permit ICOP to carry out the Subcontract works for 20 hours a day, from Monday to Saturday”.<sup>236</sup> I am mindful that, in its Reply and Defence to

---

<sup>235</sup> PRS at para 161.

<sup>236</sup> SOC 2 at para 61(f).

Counterclaim, ICOP avers that it took “all reasonable steps to keep noise levels at a minimum, and it was [TSCE’s] failures that resulted in [ICOP] being unable to work for the contractually agreed time periods”.<sup>237</sup> This pleading is inadequate because it says nothing of what TSCE’s failures were, and when asked to provide further particulars in respect of this paragraph, ICOP stated only that it repeats the above paragraph from its SOC,<sup>238</sup> *ie*, that TSCE “failed to obtain” the necessary noise permits.

102 However, as I stated above, there is no dispute that TSCE obtained the relevant permit from the NEA allowing ICOP to carry out whole-day works, six days a week (see [96] above). Failing to obtain a permit is quite distinct from a permit being varied as a result of some subsequent conduct for which I should hold TSCE liable. Indeed, because cl 4.8.5 of the LOA – as I have found – placed the obligation on ICOP to keep noise below permitted limits, the default position would be that ICOP is liable for the NEA’s issuance of the Stop Work Order unless it can show that TSCE did *something* to bring about that order through no fault of ICOP. On ICOP’s pleaded case, no such allegation is made against TSCE, and, thus, its delay claim in respect of the noise restriction issue fails. Conversely, to the extent that critical delays resulted from the Stop Work Order, such delays are to be attributed to ICOP.

103 In respect of the number of days of critical delay to be attributed to ICOP, Mr Wall assesses that there were 70 calendar days of actual critical delay which resulted from the noise restriction issue. Mr Widdowson assesses the much lower figure of 31.137 calendar days.<sup>239</sup> TSCE points out in its written

---

<sup>237</sup> R&DC2 at para 40.

<sup>238</sup> PF&BPs (7 Feb 2020) at p 42, para (kk)(ii).

<sup>239</sup> Scott Schedule at S/N 1.4.1.

submissions that Mr Wall made several calculation errors.<sup>240</sup> First, at trial, he sought to revise his calculated delay from 70 days down to 54 days, broken down into two different components – a 46.5-day delay which the noise restriction issues caused to pipe jacking works, and a further 7.5-day delay it caused to the recovery of the MTBM after it completed Drive 2 and broke through the receiving shaft. I did not allow the latter to be entered because it was not an “error” in any superficial sense, but rather, a different approach towards calculating delay in respect of which TSCE and Mr Widdowson did not have any notice.<sup>241</sup> Second, Mr Wall also admitted that he used the wrong figure in calculating the amount of time lost as a result of the noise restriction issue.<sup>242</sup> Third, Mr Wall’s calculations are based on a 22-hour working day, but the Subcontract only provides that TSCE was to obtain a 20-hour working permit.<sup>243</sup> I accept that these errors affect the reliability of Mr Wall’s calculations.

104 In the premises, I accept Mr Widdowson’s calculations of the number of days of critical delay resulting from the noise restriction issue and award TSCE liquidated damages of  $31.137 \times 1,710$ , *ie*, \$53,244.27.

### ***The insufficient pipes issue***

105 As alluded to at [66(e)] above, it is ICOP’s pleaded case that it suffered 158 working days of delay “as a consequence” of the matters I set out at [65].<sup>244</sup> In further and better particulars, ICOP then attributed parts of this 158-working day delay to *only* four issues: (a) the worksite readiness and handover issue; (b)

---

<sup>240</sup> DCS at paras 487–496.

<sup>241</sup> NEs (27 Oct 2021) at pp 136–148.

<sup>242</sup> NEs (27 Oct 2021) at pp 152–153; NEs (28 Oct 2021) at p 33 lines 21–23.

<sup>243</sup> ABOD (Vol 16) at p 301 at para 4.1(p) (read with ABOD (Vol 16) at p 287, cl 1.1.8).

<sup>244</sup> SOC2 at para 62.

the authority approvals issue; (c) the headwall issue; and (d) the noise restriction issue.<sup>245</sup> For this 158-working day delay, ICOP seeks damages to compensate the “additional overheads and expenses” it incurred, including manpower wages, equipment rental and offices leases, totalling \$2,516,774.98.<sup>246</sup> *Prima facie*, on the face of ICOP’s pleaded case, it does not appear to have suffered any delay or consequent losses as a result of the insufficient pipes issue.

106 TSCE thus responds that ICOP’s claim should be dismissed on the failure of its pleadings because “it is trite that a party is bound by its pleadings and is not at liberty to depart [therefrom]”, citing the Court of Appeal’s decision in *Sheagar s/o T M Veloo v Belfield International (Hong Kong) Ltd* [2014] 3 SLR 524 at [94].<sup>247</sup> I am mindful that the delay experts have rendered an opinion as to the number of days of critical delay associated with the insufficient pipes issue,<sup>248</sup> however, TSCE submits that that the deficiencies in ICOP’s pleadings “may not be cured by evidence in an affidavit or other form”.<sup>249</sup> For this submission, it cites an earlier decision of mine, *Bumi Geo Engineering Pte Ltd v Civil Tech Pte Ltd* [2015] 5 SLR 1322 at [56], which in turn relied on the decision of MPH Rubin J in *Abdul Latif bin Mohammed Tahiar v Saeed Husain s/o Hakim Gulam Mohiudin* [2003] 2 SLR(R) 61 at [7].

107 ICOP’s response is threefold.<sup>250</sup> First, it pleaded the events giving rise to the delay and was merely silent on the number of days to be attributed to such event. Second, in further and better particulars to an earlier version of its

---

<sup>245</sup> PF&BPs (7 Feb 2020) at pp 30–31.

<sup>246</sup> SOC2 at para 62 and “Claims”, number (8).

<sup>247</sup> DCS at para 343.

<sup>248</sup> Scott Schedule at S/N 2.1 (“Availability of Pipes and Waste Disposal”).

<sup>249</sup> DCS at para 343.

<sup>250</sup> PRS at paras 69–77.

Defence and Counterclaim,<sup>251</sup> TSCE itself took the position that pleading the total number of days of delay (266 calendar days) was sufficient, and that “any further [request for] particulars amount[s] to a request for submissions and/or matters of factual or expert evidence”.<sup>252</sup> Third, in any event, the alleged deficiency in the pleadings did not catch TSCE by surprise.

108 I accept TSCE’s general submission. As stated at [46]–[47] above, parties in technical disputes should – in my view – be held closely to their pleadings. The natural way to read ICOP’s SOC, alongside the further and better particulars it provided, is that *no days of delay* arose from the insufficient pipes, poor-quality pipes, waste disposal and unplanned cutterhead inspection issues. Its claim in respect of this issue – as well as the other three issues below – can thus be dismissed on this basis. I will, however, make three further points.

109 First, it is well-established that in a contractor’s claim for damages or an extension of time as a result of the employer’s delay, the following needs to be established: (a) that the employer-delay event occurred; (b) that the event caused the delay being claimed; (c) that the delay caused was on the critical path; and most relevantly for present purposes, (d) the *number* of critical days of delay caused by the event.

110 Second, in respect of TSCE’s alleged failure to ensure there was a sufficient quantity of pipes ready at the worksite *prior* to the commencement of Drive 2, ICOP accepts that any delay arising from this failure overlaps with the authority approvals issue.<sup>253</sup> Since I have decided this in ICOP’s favour (see

---

<sup>251</sup> D&CC (Amendment No 1) (9 Jan 2020) (“D&CC1”) at para 53(1).

<sup>252</sup> Defendant’s Further and Better Particulars (“DF&BPs”) (7 Feb 2020) at para 12.

<sup>253</sup> PCS at paras 316.1 and 317.

[77]–[81] above), my dismissal of ICOP’s claim in this regard is, in any event, inconsequential. As to ICOP’s claim that there were insufficient pipes *during* Drive 2, ICOP submits that the resulting delay was just 1.13 working days.<sup>254</sup> This is largely negligible.

111 Finally, I do not agree that TSCE’s failure to particularise the 266 calendar days of delay it allegedly suffered is equivalent to ICOP’s failure to allocate any of its 158-working days of alleged delay to the insufficient pipes, poor-quality pipes, waste disposal and unplanned cutterhead inspection issues. In TSCE’s Defence and Counterclaim, it raises seven issues allegedly resulting in 266 calendar days of delay.<sup>255</sup> When ICOP sought “full particulars” of this 266-calendar day delay, “including how [TSCE] arrived at this figure for the number of days of delay”, TSCE simply replied:<sup>256</sup>

[TSCE] repeats paragraph 54 of the [Defence and Counterclaim]. The 266 days of delay is comprised of: (a) 50 days of delay to the pipe-jacking from P5-1 to P5-7 as compared to the time allocated in the [17 August 2018 WP]; and (b) 216 days of delay to the pipe-jacking from P5-2 to P5-1 as compared to the time allocated in the [17 August 2018 WP].

Pending discovery, the administration of interrogatories and/or the provision of expert evidence these are the best particulars which [TSCE] can provide.

112 By contrast, as stated at [105] above, ICOP chose to ascribe specific days of its total 158-working day claim, to the worksite readiness and handover issue, the authority approvals issue, the headwall issue and the noise restriction issue. By doing so, it left no room for the other four issues it raised in respect of its

---

<sup>254</sup> PCS at paras 316.2 and 318–324.

<sup>255</sup> D&CC4 at para 54 (paras 54(3) and (4) may be treated as a single issue).

<sup>256</sup> DF&BPs (1 July 2020) at para 1.

delay claim, which was not subsequently amended. ICOP did not need to take this course of action; but, since it did, it is bound by its approach.

113 I should also be clear that my decision does not prejudice ICOP for being more specific and particular, unlike TSCE. TSCE is not benefitting from its less particularised approach. Rather, it bears the ordinary risk from mounting what is typically referred to as a “global” or “composite” delay claim. This course of action comes with certain evidentiary challenges, and when a party chooses this approach, it has to manage those challenges. In *Walter Lilly & Co Ltd v Mackay* and another [2012] EWHC 1773, Akenhead J reviewed the authorities governing “global” or “composite claims (at [473]–[492]) and distilled the following principles (at [486]):

(a) Ultimately, claims by contractors for delay or disruption related loss and expense must be proved as a matter of fact. Thus, the Contractor has to demonstrate on a balance of probabilities that, first, events occurred which entitle it to loss and expense, secondly, that those events caused delay and/or disruption and thirdly that such delay or disruption caused it to incur loss and/or expense (or loss and damage as the case may be)...

(c) It is open to contractors to prove these three elements with whatever evidence will satisfy the tribunal and the requisite standard of proof. There is no set way for contractors to prove these three elements...

(d) There is nothing in principle 'wrong' with a 'total' or 'global' cost claim. *However, there are added evidential difficulties (in many but not necessarily all cases) which a Claimant contractor has to overcome. It will generally have to establish (on a balance of probabilities) that the loss which it has incurred (namely the difference between what it has cost the contractor and what it has been paid) would not have been incurred in any event. Thus, it will need to demonstrate that its accepted tender was sufficiently well priced that it would have made some net return. It will need to demonstrate in effect that there are no other matters which actually occurred (other than those relied upon in its pleaded case and which it has proved are likely to have caused the loss)...*



(e) The fact that one or a series of events or factors (unpleaded or which are the risk or fault of the Claimant contractor) caused or contributed (or cannot be proved not to have caused or contributed) to the total or global loss does not necessarily mean that the Claimant contractor can recover nothing. It depends on what the impact of those events or factors is...

(f) Obviously, there is no need for the court to go down the global or total cost route if the actual cost attributable to individual loss causing events can be readily or practicably determined...

(g)... In principle, unless the contract dictates that a global cost claim is not permissible if certain hurdles are not overcome, such a claim may be permissible on the facts and subject to proof.

[emphasis added]

114 Akenhead J also cited (at [479] – [480]) Lord Macfadyen’s observation in the Scottish case of *John Doyle Construction Ltd v Laing Management (Scotland) Ltd* [2012] BLR 393 , that:

Advancing a claim for loss and expense in global form is therefore a risky enterprise. Failure to prove that a particular event for which the defender was liable played a part in causing the global loss will not have any adverse effect on the claim, provided the remaining events for which the defender was liable are proved to have caused the global loss. On the other hand, proof that an event played a material part in causing the global loss, combined with failure to prove that that event was one for which the defender was responsible, will undermine the logic of the global claim. Moreover, the defender may set out to prove that, in addition to the factors for which he is liable founded on by the pursuer, a material contribution to the causation of the global loss has been made by another factor or other factors for which he has no liability. If he succeeds in proving that, again the global claim will be undermined.

115 Since this is the approach TSCE adopted, its delay claim stands and falls by these principles. The more straightforward manner in which ICOP’s case was advanced facilitates simpler, itemised treatment of each head of delay subject to consideration of opposing causal arguments as well as evidence by the delay experts on whether a work item was on the critical path. ICOP’s submission that TSCE’s claim suffers the same deficiencies – or, as its counsel

puts in its written reply, “what is sauce for goose is sauce for the gander”<sup>257</sup> – is not an accurate complaint. I therefore dismiss ICOP’s delay claim in respect of the insufficient pipes issue.

***The poor-quality pipes issue***

116 I dismiss this aspect of ICOP’s delay claim for the same reasons as set out at [105]–[114] above. I will, however, make two parenthetical observations about ICOP’s case on this issue. First, in its written closing, ICOP does not make substantive submissions on the delay which resulted from the poor-quality pipes issue. In a table summarising its and TSCE’s delay claims, ICOP suggests that it incurred 1.13 days of delay from having to deal with the “leaking and clean up” of pipes. However, the cross-reference ICOP makes to the main body of its written submissions is to a paragraph which concerns the insufficient pipes issue.<sup>258</sup> It is therefore not entirely clear what ICOP’s submissions in respect of the *poor-quality pipes issue* are.

117 Second, ICOP does make submissions on this issue in its written reply.<sup>259</sup> These submissions point to contemporaneous pieces of evidence which show that ICOP had brought to TSCE’s attention, design defects with the jacking pipes to be used for Drive 2. In making these submissions, however, ICOP suggests that “[t]o the extent that TSCE relies on the Delay Experts’ assessment,<sup>260</sup> it should be noted that the experts did not have the benefit of the parties’ evidence and AEICs. TSCE has not provided any evidence as to its

---

<sup>257</sup> PRS at para 76.

<sup>258</sup> PCS at p 196.

<sup>259</sup> PRS at paras 131–137.

<sup>260</sup> Which may be found at DCS at paras 363–368.

defence that the defective leaking pipes did not cause delays”.<sup>261</sup> It is difficult to understand how this argument aids ICOP. If the delay experts were not presented with evidence and, therefore, their calculation of the delay associated with the poor-quality pipes issue cannot be relied upon, I do not see how I am supposed to resolve this issue in ICOP’s favour. It is *ICOP’s* burden to prove not only that the delaying event took place (*ie*, that TSCE supplied defective pipes), but also the number of days of delay which this event actually caused. So, even if the issue with its pleadings is put aside, on ICOP’s own position, this is not a claim which I can resolve in its favour on the evidence put before me.

***The waste disposal issue***

118 Again, I dismiss this aspect of ICOP’s delay claim for the same reasons as set out at [105]–[114] above. In any event, like the insufficient pipes issue, the delay ICOP claims to have suffered in connection with this issue is insubstantial; just two days between 15 and 17 October 2018.<sup>262</sup> The effect of ICOP’s deficient pleadings is therefore minimal.

***The unplanned cutterhead inspection issue***

119 I also dismiss this claim for the same reasons stated at [105]–[114] above. The delay allegedly suffered in respect of this issue is one day,<sup>263</sup> so once again, the overall impact on ICOP’s claim is minimal.

---

<sup>261</sup> PRS at para 135.

<sup>262</sup> PCS at para 328 and p 195.

<sup>263</sup> PCS at para 339 and p 195.

***The slow pipe jacking issue***

120 In essence, TSCE complains that ICOP’s pipe jacking works in respect of Drive 2 – even after accounting for the decrease in productivity caused by the noise restriction issue – was slow. In support of this claim, TSCE relies chiefly on Mr Widdowson’s identification of various delays which have either not been explained or have been recorded in the daily site reports as matters relating to pipe jacking works. Mr Widdowson calculates that these delays add up to 28.8 days.<sup>264</sup> As a factual basis for this claim, TSCE’s Mr Jung gave evidence that these delays were caused by ICOP’s slow pipe jacking works.<sup>265</sup> Without further challenge, TSCE submits that I should accept such evidence as being sufficient to establish TSCE’s case on a balance of probabilities.

121 Conversely, ICOP has only challenged the factual basis of this claim by way of an assertion in its closing submissions that some of the delays identified were instead caused by TSCE.<sup>266</sup> Counsel for ICOP did not directly challenge Mr Jung’s evidence on this point during cross-examination. Accordingly, there is little which I can make of ICOP’s bare assertion that the delays were not caused by ICOP, but rather TSCE. Indeed, my view is that this bare assertion is not enough to tip the scales of probability back in favour of ICOP.

122 ICOP also mounts challenges against the correctness of Mr Widdowson’s calculations.<sup>267</sup> First, ICOP claims that Mr Widdowson admits that the 28.8 days of delay he calculated arise in respect of matters which have not been pleaded by TSCE. This is incorrect and ICOP has misread Mr

---

<sup>264</sup> CBAEIC (Vol 12) at p 8550.

<sup>265</sup> CBAEIC (Vol 12) at pp 8855–8858, paras 314–317 (Jung Jae Hun’s AEIC)

<sup>266</sup> PCS at para 387.

<sup>267</sup> PCS at paras 383–389.

Widdowson’s report. What Mr Widdowson in fact states is that these 28.8 days are above and beyond from *other* delays which TSCE has raised in its pleadings, *eg*, those arising from the noise restriction issue. Second, ICOP argues that Mr Widdowson should not have assessed the absence of work on public holidays against ICOP. However, I agree with TSCE’s submission that there is nothing in the Subcontract which provided allowance for public holidays.<sup>268</sup> Accordingly, this should be taken as increased cost factored into the contract price. Third, ICOP claims that Mr Widdowson did not give credit for a 10-day float to which they were entitled. Having reviewed Mr Widdowson’s report,<sup>269</sup> I am satisfied that he did in fact apply a 10-day float in ICOP’s favour and that the 28.8-day delay he arrived at was *after* such credit had been given.

123 Finally, ICOP contends that Mr Widdowson’s calculations do not grant ICOP the full 66 working days it was entitled to take to complete the pipe jacking works for Drive 2.<sup>270</sup> To make this point, ICOP submits:<sup>271</sup>

It is not in dispute that the pipe jacking works ultimately took 170 days, i.e., from 29 August 2018 to 15 January 2019. However, ICOP submits that insofar as TSCE caused 55.25 calendar days of delay due to the [noise restriction issue], 1 day of delay due to the [unplanned cutterhead inspection issue] and 1.33 days of delay due to the [insufficient and poor quality pipes issues], then the works only exceeded the provisioned time period by 6 calendar days.

124 This argument is confusing for many reasons. First, it is unclear whether the “170 days” refers to calendar days or working days. Second, if ICOP meant calendar days, then that is also confusing since the period from 29 August 2018

---

<sup>268</sup> DRS at para 309.

<sup>269</sup> CBAEIC (Vol 12) at p 8550.

<sup>270</sup> Annex 1: Applicable Baseline Programme, WorkCode 1.1.2.1.1.10.

<sup>271</sup> PCS at para 385.

to 15 January 2019 (both dates inclusive) only comprises 140 calendar days. In any event, since the applicable baseline programme sets out durations in *working* days, that is what should have been indicated in ICOP’s submissions. The period of 29 August 2018 to 15 January 2019 (both dates inclusive) includes 20 Sundays and thus has 120 working days. Third, even if the number of working days from 29 August 2018 to 15 January 2019 is accurately stated, it is unclear how ICOP arrived at an excess of six days.

125 That said, there is some merit to ICOP’s slightly confusing submission. Delay can either be assessed across a period during which multiple tasks need to be completed or it may be assessed in respect of a particular task. The latter is more appropriate here since TSCE’s allegation is that the *rate* at which ICOP carried out this task (*ie*, pipe jacking works) was slow. The performance of a task can only be said to be slow relative to the number of days the parties agreed it would take to complete, which ICOP suggests is 66 working days based on the 17 August 2018 WP. TSCE’s only response to this is that the 17 August 2018 WP is not the applicable baseline programme.<sup>272</sup> However, the 8 January 2018 WP, which I have determined to be the applicable baseline programme *also* provides that ICOP has 66 working days to complete pipe jacking works.<sup>273</sup> I therefore reject TSCE’s argument.

126 In my view, ICOP should be held liable for its “slowness” in carrying out the pipe jacking works only to the extent that it exceeded the amount of time it would have taken in the ordinary course, had there been no delay. That is, 120 working days less 66 working days, less the 31.137 days of critical delay already determined in TSCE’s favour in respect of the noise restriction issue. I do not

---

<sup>272</sup> DRS at para 308.

<sup>273</sup> Annex 1: Applicable Baseline Programme, WorkCode 1.1.2.1.1.10.

give any credit to ICOP in respect of the insufficient pipes issue, poor-quality pipes issue, and unplanned cutterhead inspection issue for the reasons stated at [105]–[117] and [119] above. This amounts to 22.86 working days. Accordingly, I award TSCE liquidated damages of  $22.86 \times 1,710$ , *ie*, \$39,090.60.

***The slow demobilisation issue***

127 The slow demobilisation issue concerns a period after ICOP completed pipe jacking works for Drive 2, from 16 January to 13 March 2019. It is broken down into three events giving rise to sub-delays:<sup>274</sup>

(a) First, nine working days of delay from 16 to 25 January 2019 resulting from ICOP’s allegedly slow removal of the MTBM from the receiving shaft of Drive 2 (*ie*, Shaft P5-1). According to the applicable baseline programme, recovery of the MTBM was supposed to take only one day.<sup>275</sup>

(b) Second, 16 working days of delay from 26 January to 14 February 2019 resulting from the “completion of remaining pipe jacking” as well as the removal of intermediate jacking stations (“IJS”).<sup>276</sup> The applicable baseline programme provided that ICOP had a total of ten working days to complete this task.<sup>277</sup>

(c) Lastly, six working days of delay from 14 to 20 February 2019 to turnover Shaft P5-1. The applicable baseline programme did not

---

<sup>274</sup> PCS at para 392; DRS at para 312; CBAEIC (Vol 12) at p 8556.

<sup>275</sup> Annex 1: Applicable Baseline Programme, WorkCode 1.1.2.1.1.11.

<sup>276</sup> CBAEIC (Vol 12) at p 8554, para 5.14.4.

<sup>277</sup> Annex 1: Applicable Baseline Programme, WorkCode 1.1.2.1.1.12.

accord any working days for ICOP to handover the shaft to TSCE.<sup>278</sup>  
This seems logical since time was allocated separately for the recovery of the MBTM and demobilisation.

128 ICOP accepts that the attributability of the first nine-day delay depends on the party which succeeds in respect of Issue 4 (see [37]–[48] above). This is because, without establishing a breach on TSCE’s part in relation to Issue 4, ICOP does not have a basis to shift the blame for this delay to TSCE. I therefore find ICOP liable for this nine-working day delay.

129 ICOP also does not seriously dispute liability in respect of the delays resulting from the second and third events set out at [127(b)] and [127(c)] above.<sup>279</sup> It makes just three brief points. First, that it should be given credit for the “12 calendar days” allotted for demobilisation in the applicable baseline programme. I accept this, but, as I have stated above, this should be framed in terms of the number of *working* days, which was ten. Second, that it should also be given credit for the decrease in productivity caused by the noise restriction issues. As I have not determined that issue in ICOP’s favour, no credit is to be given. Lastly, that it should also be given credit for the fact that its demobilisation was slowed by the poor-quality pipes supplied by TSCE. I have not determined the poor-quality pipes issue in ICOP’s favour (see [116]–[117] above) on the basis of its defective pleadings. However, in respect of *this* issue, ICOP also says nothing about the extent to which they should be given credit. Its submission is a bare one:<sup>280</sup>

---

<sup>278</sup> Annex 1: Applicable Baseline Programme, WorkCode 1.1.2.1.1.13.

<sup>279</sup> PCS at paras 395–397.

<sup>280</sup> PCS at para 397.



Finally, ICOP's demobilisation from Shaft P5-1 and handover of Shaft P5-2 was also affected by the defective and leaking pipes which had been provided by TSCE.

130 There is nothing I can make of this in terms of determining whether the number of days of delay to be attributed to ICOP should be reduced on this basis. I therefore do not make any reduction and find that ICOP is liable for a further 12 working days of delay (16 + 6 – 10). Based on these delays, I award TSCE liquidated damages amounting to  $21 \times 1,710$ , *ie*, \$35,910.

***The removal of the MTBM issue***

131 The crux of TSCE's claim in respect of this issue is that ICOP wrongfully removed its MTBM from the worksite after the completion of Drive 2 from 13 February to 13 March 2019 (which was when the Subcontract was terminated by ICOP: see [143] below). The MTBM was removed and shipped to Malaysia to be reassembled, tested and commissioned. To refresh, the machine needed to be reassembled because it had been disassembled to facilitate removal from Shaft P5-1 (see [37]–[48] above).

132 TSCE makes fairly forceful submissions as regards why ICOP removed the MTBM from the worksite despite the Subcontract works being substantially delayed from its planned completion. It submits that “the irresistible conclusion from ICOP's actions is that it simply wanted to remove the MTBM ... and hold TSCE ransom as it attempted to re-negotiate the Subcontract on terms that were more favourable to ICOP”.<sup>281</sup> I do not think that such allegations are necessary for the resolution of this dispute.

---

<sup>281</sup> DCS at para 532.

133 The point is simply *when* ICOP was obliged to commence work for the third drive (which was never started). ICOP relies on the fact that it was entitled to receive a notice to proceed 45 days in advance of when it was expected to begin mobilising its equipment.<sup>282</sup> TSCE refers to meetings which took place on 21 and 22 January 2019 in which the parties agreed that the third drive would commence on 11 February 2019.<sup>283</sup> TSCE accepts that no notice to proceed was issued, however, it seems to make the submission that the 11 February 2019 date superseded the requirement for it to issue a notice to proceed.<sup>284</sup> Though, it is not very clear on what legal basis TSCE makes this claim.

134 TSCE does not plead that the alleged agreement to commence the third drive on 11 February 2019 gave rise to a variation, some form of estoppel or waiver such that ICOP could not rely on its entitlement to receive a notice to proceed ahead of when it was expected to mobilise its equipment to commence the third drive. In the circumstances, it is unclear what I am to make of TSCE's alleged agreement and I dismiss this aspect of its counterclaim.

### ***Summary of conclusions on Issue 7***

135 I determine the worksite readiness and handover issue as well as the authority approvals issues in ICOP's favour. In respect of these issues, I find TSCE liable for 60 days of critical delay and award ICOP \$401,338.47 in damages for the standby costs it incurred in respect of such delay. I do not award ICOP the cost of renting the MTBM.

---

<sup>282</sup> PCS at para 401; ABOD (Vol 16) at p 299.

<sup>283</sup> DCS at para 521; ABOD (Vol 24) at p 611.

<sup>284</sup> DRS at para 322.

136 I determine the headwall issue, the noise restriction issue, the slow pipe jacking issue and the slow demobilisation issue in TSCE's favour. In total, I find ICOP liable for causing 123.997 days of critical delay and award TSCE liquidated damages at a rate of \$1,710 per day. This amounts to \$212,034.87.

137 I dismiss ICOP's claims in respect of the insufficient pipes issue, the poor-quality pipes issue, the waste disposal issue and the unplanned cutterhead inspection issue. I also dismiss TSCE's claim in respect of the removal of the MTBM issue. I make no award in respect of these claims.

138 Lastly, I return to ICOP's entitlement in respect of Issue 6 (see [52]–[53] above). The delay claim I have determined in favour of ICOP concerns standby costs it incurred in April, May and June 2018 (see [84] above). This overlaps slightly with ICOP's claim for the cost of additional works and services it provided to TSCE (from June 2018 to May 2019). Unfortunately, the quantum experts Mr Wall and Mr Snadden have not provided a monthly breakdown of the costs which they agree ICOP incurred.<sup>285</sup> They have only provided the overall figure of \$29,230.05 which they agree ICOP incurred subject to the avoidance of double recovery in respect of the delay claims ICOP brings. Equally, although the parties agree that ICOP is entitled to recover a maximum of \$29,230.05,<sup>286</sup> they do not provide assistance in respect of how to deal with partial overlaps. In the premises, I will simply apply a proportionate reduction to the sum of \$29,230.05 based on the sums ICOP pleaded it incurred.<sup>287</sup> For the month of June 2018, ICOP pleads that it incurred \$9,945.83 and for the whole period of June 2018 to May 2019, it pleads that it incurred \$54,438.66. The sum

---

<sup>285</sup> JS(Q) at para 2.2.

<sup>286</sup> PCS at para 189; DRS at para 364.

<sup>287</sup> SOC2 at para 54.

of \$9,945.83 is therefore 18.27% of ICOP’s total pleaded expenditure for these additional works and services. Accordingly, I will reduce the agreed sum of \$29,230.05 by this proportion, which yields \$23,889.72. Adding 7% GST to this sum, ICOP is entitled to receive \$25,562. I am mindful that this is not a precise way to dispose of the matter, but given the evidence before me, and the largely *de minimis* quantum of this claim relative to the whole dispute, I find that it is sufficiently fair and expeditious.

### **Issue 8: ICOP’s termination of the Subcontract**

#### ***Whether ICOP’s termination of the Subcontract was lawful***

139 As stated at several points above, ICOP terminated the Subcontract on 13 March 2019. In its SOC, ICOP relies exclusively on cl 6 to “Appendix F to the LOA” as the basis on which it claims to have validly terminated the Subcontract.<sup>288</sup> This appendix, dated 22 October 2016, is the final quotation ICOP issued to TSC for the Project, and one of several documents constituting the whole of the Subcontract.<sup>289</sup> This clause reads:<sup>290</sup>

#### **6. Payment conditions**

Work progress has to be stated every month in a document called Validated Monthly Progress Report (VMPR). VMPR has to be signed by the parties within the first 15 days of the following month. ICOP will prepare the invoices on a monthly base accordingly or to be agreed upon contract award. The payment could also be form as accordance to Work done fully remeasureable (Shaft inner wall to wall). The invoice has to be paid after 30 days from the invoice date.

- 10% Advance payment 30 days after signing the final contract (To be discussed)
- 87% monthly based on VMPR (To be discussed)

---

<sup>288</sup> SOC2 at paras 67 and 69.

<sup>289</sup> ABOD (Vol 16) at p 287, cl 1.1.8.

<sup>290</sup> ABOD (Vol 16) at p 270, cl 6.

- 3% as Retention by receipt of completion certificate (To be discussed)

In case ICOP has fulfilled its obligation under the contract and can for reasons which are beyond the control of ICOP not start or continue with the work in a timely manner, ICOP shall have the right to terminate the work and rendering services. TSC has to fully reimburse ICOP for all its cost for bring, repatriating and maintain all the equipment and staff. All payments shall be made in SGD given the above payment schedule. The payment schedule is structured to be cash neutral, hence no financing costs are assumed in the above prices.

140 Relying on this clause, ICOP asserts two alternative bases which it claims prevented it from continuing its work in a timely manner, and which justifies its termination of the Subcontract on 13 March 2019.

(a) The first basis is the Stop Work Order (see [97] above) which ICOP claims was beyond its control and prevented it from completing the Subcontract works in a timely manner.<sup>291</sup>

(b) The second basis is that ICOP was unable to commence work on the third drive because TSCE had yet to complete the receiving shaft for this drive. TSCE was also in the process of reconstructing the headwall and thrust wall for Shaft P5-2 (the launching shaft for the third drive), thus, ICOP contends, it was able to terminate the Subcontract because work could not be continued in a timely manner.<sup>292</sup>

141 It is important to highlight that the termination clause also prescribes a precondition for ICOP's termination. Namely, that ICOP must have "fulfilled its obligation under the contract".

---

<sup>291</sup> SOC2 at para 68.

<sup>292</sup> SOC2 at para 69.

142 With this, ICOP’s claim that it lawfully terminated the Subcontract can be dismissed quite simply. First, its claim as premised on the Stop Work Order cannot succeed in light of my decision in respect of the noise restriction issue (see [95]–[104] above). Second, ICOP’s claim that it could not continue works in a timely manner because the two shafts for the third drive were not ready is, in my view, contrived. The Subcontract works were substantially delayed, both by the actions of ICOP and TSCE. ICOP has not put forth anything to show that TSCE’s actions following Drive 2 somehow further prevented the Subcontract works from being continued in a timely manner. Finally, and in any event, given the various delays I have found are attributable to ICOP, it is also clear that ICOP cannot be said to have “fulfilled its obligation[s] under the [Subcontract]”.

143 I therefore find that ICOP was not entitled to terminate the Subcontract as it did on 13 March 2019. It is accordingly liable for wrongful termination. On 22 March 2021, I directed by HC/ORC 2422/2021 that this trial was to be bifurcated if TSCE successfully made out its counterclaim for wrongful termination against ICOP. Accordingly, I order that the parties proceed to a hearing to determine the quantum for which ICOP is liable (the “Quantum Hearing”).

***ICOP’s claim for outstanding sums due and retention sums***

144 There are two claims related to ICOP’s termination of the Subcontract.

145 First, beyond<sup>293</sup> the fees ICOP claims for completed but unpaid works under Issue 5 (see [49]–[51] above), it also seeks to recover \$72,711.80 which it avers represents the “outstanding balance that [it] is entitled to claim for

---

<sup>293</sup> PCS at para 370.

mobilisation and demobilisation works”.<sup>294</sup> TSCE disputes liability on the basis that ICOP’s entitlement to this sum turns on whether it was entitled to lawfully terminate the Subcontract, which, as I have found it was not.<sup>295</sup> The connection which TSCE draws between ICOP’s entitlement to this \$72,711.80 claim and the lawfulness of its termination of the Subcontract is this. Essentially, TSCE asserts that ICOP’s demobilisation of its equipment after Drive 2 was not an act done in the ordinary performance of the Subcontract. Instead, it was an unlawful abandoning of the Subcontract works. As a party may not take advantage of its own wrongful conduct (see *Evergreat Construction Co Pte Ltd v Presscrete Engineering Pte Ltd* [2006] 1 SLR(R) 634 at [51]), ICOP should not be allowed to recover this sum.<sup>296</sup>

146 I do not accept TSCE’s argument. First of all, I am not satisfied that ICOP specifically and intentionally demobilised its equipment with the cynical view to abandoning the Subcontract or “holding TSCE ransom” (see [132] above).<sup>297</sup> As such, I am not persuaded that ICOP was taking advantage of its own wrong. Second, in any case, the lawfulness of ICOP’s termination of the Subcontract is not, in my view, relevant to whether ICOP is entitled to receive payment for its mobilisation and demobilisation works.<sup>298</sup> Whether performed fully or partially, ICOP needed to mobilise and demobilise its equipment and this is a fee for which the Subcontract specifically provided.<sup>299</sup> If ICOP failed to complete the works it was supposed to under the Subcontract *and* it also

---

<sup>294</sup> SOC2 at para 70 and “Claims”, number (9).

<sup>295</sup> DCS at para 586; DRS at para 356.

<sup>296</sup> DCS at paras 587–588; DRS at para 357.

<sup>297</sup> DCS at para 532.

<sup>298</sup> ABOD (Vol 16) at p 294, S/O 1.0; cross-reference JS(Q) at para 2.1.1(A).

<sup>299</sup> ABOD (Vol 16) at p 294, S/O 1.0.

wrongfully terminated the Subcontract, TSCE is entitled to sue for damages. Thus, the correct approach is not to dismiss ICOP's claim in this regard. Instead, the fact that TSCE would need to incur further mobilisation and demobilisation costs in respect of the new microtunnelling contractor it needs to engage to complete the Subcontract works is a matter which can be taken into account in assessing the extent of ICOP's liability for its wrongful termination.

147 I therefore award ICOP \$72,711.80.

148 The second claim connected to ICOP's termination of the Subcontract concerns fees which TSCE has retained pursuant to cll 7.2 and 7.3 of the LOA. This clause provides:<sup>300</sup>

**7. Process Payments and Retention Monies**

...

7.2 We shall be entitled to deduct a sum representing 3% of the value of work certified and/or assessed by us to be payable to you being retention monies, to be held as security for your due and proper performance of the [Subcontract], provided always that the maximum limit of the retention monies shall not exceed 3% of the [Subcontract] Sum. Such retention monies shall be released to you as set out in the General Conditions of [Subcontract].

7.3 We shall make payment in respect of items of work / claim that we had certified and/or assessed in our interim payment certificate or payment response issued in accordance with clause 11 of the General Conditions of [Subcontract] within (14) days of such interim payment certificate or payment response or within (21) days from the date of your invoice, whichever is earlier, subject always to our right to deduct such sums that we are entitled to under the terms of the [Subcontract], including but not limited to retention monies and any other deductions and/or back charges that we are entitled to under the terms and conditions of this [Subcontract] and/or under law. We shall within

---

<sup>300</sup> ABOD (Vol 16) at p 291 (read with p 281).



21 days from the date of receipt of your progress payment claim, issue an interim payment certificate or payment response to you.

“We” in these clauses refer to TSCE.

149 ICOP’s contention is that, following its termination of the Subcontract, TSCE is no longer entitled to retain such monies, which it avers amounts to \$61,517.48.<sup>301</sup> TSCE resists this claim on the basis that ICOP has wrongfully terminated the Subcontract and, accordingly, TSCE is “entitled to retain and apply these monies to set off ... against the losses suffered by TSCE as a result of ICOP’s breaches”.<sup>302</sup>

150 I appreciate TSCE’s point, but, as I will address in my conclusion at [162] below, it is appropriate in this case to order a stay of execution on all of my awards until after the Quantum Hearing. There is, accordingly, no need for me to separately order that TSCE be allowed to retain this sum of \$61,517.48. To be clear, however, there is no dispute that ICOP has earned and is entitled to be paid this sum. The issue is whether TSCE should benefit from the security accorded by being allowed to keep money already in hand, at least temporarily. On the basis of my general stay of execution, TSCE will indeed benefit from such security, but I should also be clear that ICOP is entitled to receive the \$61,517.48 in fees which TSCE has retained under cll 7.2 and 7.3 of the LOA. If the value of TSCE’s claim exceeds ICOP’s, this sum will serve to set off ICOP’s liability; but if TSCE’s claim does not exceed ICOP’s, ICOP is entitled to recover it alongside all other sums which I have awarded it.

---

<sup>301</sup> SOC2 at para 71 and “Claims”, number (10).

<sup>302</sup> DRS at para 367.

### Issue 9: The Performance Bond

151 As mentioned at [11(i)] above, ICOP furnished a Performance Bond for the sum of \$570,000 to secure its performance of the Subcontract. Sometime in October 2019, after ICOP *purported* to terminate the Subcontract on 13 March 2019 (ICOP’s termination is “purported” given my decision in respect of Issue 8 above: see [139]–[150]), TSCE called on the full sum of this Performance Bond.<sup>303</sup> ICOP now seeks the recovery of the full sum on the basis that TSCE’s call on the Performance Bond was wrongful. To determine whether ICOP’s claim should succeed, the terms of the Subcontract governing the Performance Bond need to be examined.

152 Clauses 6.1 and 6.4 of the Subcontract provide:<sup>304</sup>

6.1 [ICOP] shall, within 14 working days of the acceptance of this Letter of Award, at [ICOP’s] own expense provide as security for the due performance and observance of the [Subcontract] a cash payment as a security deposit (“Cash Deposit”) or in the alternative submit to us an on-demand performance bond (“Performance Bond”) issued by BNP Paribas Singapore, or in the alternative by an insurer, acceptable to us and in the form given in Appendix G enclosed to the Supplemental Letter.

6.4 For the purposes of this clause, the Cash Deposit or the cash proceeds of any demand made on the Performance Bond shall be referred to as the Security Deposit. Subject always to ICOP being first afforded the opportunity to rectify any breach or default under the [Subcontract], [TSCE] may, with seven (7) working days’ notice, *use the Security Deposit to make good any cost, expense, loss or damage sustained by [TSCE] as a result of any breach of or default under the [Subcontract] by [ICOP] or in satisfaction of any sum due from [ICOP] to [TSCE] under the [Subcontract]*. If the amount of the Security Deposit used to make good any cost, expense, loss or damage is greater than the amount of cost, expense, loss, or damage actually incurred by [TSCE], [TSCE] shall pay the difference interest-free to [ICOP]

---

<sup>303</sup> SOC2 at para 74; D&CC4 at para 60A.

<sup>304</sup> ABOD (Vol 16) at p 258, cll 6.1 and 6.4.

without thirty (3) days after the issuance of the [Subcontract]  
Expire of DLP Certificate.”

[emphasis added]

153 From the emphasised text, it is clear that there are two basic requirements for TSCE to validly call on the Performance Bond: (a) ICOP must have breached the Subcontract; and (b) such breach must have *actually* caused TSCE to sustain “cost, expense, loss or damage”. Given my decision on Issue 7 above, it logically follows that requirement (a) is satisfied.

154 Whether requirement (b) is satisfied, however, is not a matter which can be resolved at this juncture. It is a question which needs to be determined at the Quantum Hearing. If it is found at the Quantum Hearing that TSCE suffered anything less than \$570,000 of cost, expense, loss or damage as a result of ICOP’s breaches as determined above, it is clear from cl 6.4 that TSCE would be obliged to return the excess to ICOP, interest-free. I therefore reserve my decision on Issue 9 until after the Quantum Hearing.

#### **Issue 10: Counterclaim for diesel**

155 The MOR provided that ICOP was obliged to provide electricity for the generator used at the worksite. TSCE was to supply the diesel for the generator, but ICOP was obliged to pay TSCE the cost of the diesel supplied at a fixed rate of \$0.75 per litre.<sup>305</sup> TSCE’s claim is for unpaid diesel supplied and ICOP admits this claim.<sup>306</sup> I therefore award TSCE the sum claimed and admitted, \$106,825.59 (this is already inclusive of 7% GST).

---

<sup>305</sup> ABOD (Vol 16) at p 263, S/O 1.10 (Matrix of Responsibilities).

<sup>306</sup> R&DC2 at paras 65–66; PCS at para 404.

### **Issue 11: Counterclaim for slurry disposal**

156 This claim succeeds partially, and I award TSCE \$83,930.

157 Slurry is the waste material removed from the ground in the course of carrying out tunnelling works. It includes both solid and liquid waste. In brief, TSCE claims a backcharge sum for the cost of slurry disposal for both Drives 1 and 2, such claim being for the sum of \$96,392.40.<sup>307</sup> ICOP does not dispute liability for this head of cost, but contends that the sum owing is only \$83,930. In refuting liability for the additional \$12,462.40 claimed, ICOP submits that TSCE’s figure is unsupported by evidence, and accordingly, ICOP’s “position on the amount attributable should be preferred”.<sup>308</sup>

158 I accept ICOP’s submission. Even TSCE’s own quantity surveyor, Mr Snadden, concedes that he was not able to “identify the basis and evidence utilised by either [ICOP] or [TSCE] to establish the backcharge figures claimed”. The only information he had to assess the quantum of TSCE’s slurry disposal claim were: (a) the agreed cost of slurry disposal per cubic metre of solid or liquid waste (\$50/m<sup>3</sup> of solid waste and \$30/m<sup>3</sup> of liquid waste); and (b) the estimated volume of liquid and solid waste which would likely be generated per day of tunnelling works in respect of the DN1200mm and DN1600mm Pipelines. These figures were stated in the MOR.<sup>309</sup> Relying on this and the length of the DN1200mm and DN1600mm Pipelines actually constructed by ICOP, Mr Snadden estimates that TSCE would have spent \$155,696.80 on slurry disposal.<sup>310</sup> On this footing, TSCE argues that, because

---

<sup>307</sup> DCS at para 601.

<sup>308</sup> PCS at para 405; also see NEs (20 Oct 2021) at p 97 line 16 to p 104 line 21.

<sup>309</sup> ABOD (Vol 16) at p 264, S/O 1.20 (Matrix of Responsibilities).

<sup>310</sup> CBAEIC (Vol 9) at pp 6327–6329, paras 150–157 (Mr Snadden’s Expert Report).

Mr Snadden’s estimate substantially exceeds the backcharges identified both by it and ICOP, “[its] higher estimate of the quantities of slurry disposal is more likely to be accurate than ICOP’s lower estimate”.<sup>311</sup>

159 This is insufficient. When concerned with sums of money *actually* spent, there must be at least some primary evidence of the expenditure. For example, if TSCE had adduced evidence of the volume waste generated on at least some of the days in respect of Drives 1 and 2, it could have been determined whether the estimates in the MOR were generally accurate, and thus, whether Mr Snadden’s approach could be accepted. Without evidence to this effect, the value of TSCE’s claim is purely conjectural. As TSCE bears the burden of proof, I only allow this claim to the extent of ICOP’s admission.

### Conclusion and orders

160 I direct that parties proceed to the Quantum Hearing to determine ICOP’s liability in respect of its wrongful termination of the Subcontract. In this regard, I reiterate my observations at [12] and [151]–[154] above in relation to the Advance Payment Bond and the Performance Bond respectively. The relevant sums are to be taken into account in determining the net award in favour of either ICOP or TSCE following the Quantum Hearing.

161 My awards, following this hearing, are as follows:

- (a) In light of my decisions on Issues 1, 2, 5, 6, 7 and 8, I find that TSCE is liable to pay ICOP **\$1,333,298.52**. This figure represents the sum of \$76,538.25 (awarded in relation to Issue 1), \$83,351.27 (awarded in relation to Issue 2), \$612,279.25 (awarded in relation to Issue 5),

---

<sup>311</sup> DCS at para 603.

\$25,562 (awarded in relation to Issue 6), \$401,338.47 (awarded in relation to Issue 7), \$72,711.80 and \$61,517.48 (both of which are awarded in relation to Issue 8).

(b) In light of my decisions on Issues 7, 10 and 11, I find that ICOP is liable to pay TSCE **\$402,790.46**. This figure represents the sum of \$83,790 (awarded in relation to the headwall issue under Issue 7), \$53,244.27 (awarded in relation to the noise restriction issue under Issue 7), \$39,090.60 (awarded in relation to the slow pipe jacking issue under Issue 7), \$35,910 (awarded in relation to the slow demobilisation issue under Issue 7), \$106,825.59 (awarded in relation to Issue 10) and \$83,930 (awarded in relation to Issue 11).

162 I order a stay of execution in respect of these payments.

163 Four submissions are made by TSCE in support of an order for a stay of execution. First, the bifurcation of the trial and the pending Quantum Hearing constitute “special circumstances” which justify the grant of a stay.<sup>312</sup> Second, TSCE “undoubtedly” has a right of set off against ICOP given how closely it and ICOP’s claims are connected.<sup>313</sup> Third, if a stay is not granted, TSCE’s right of set off will essentially be extinguished.<sup>314</sup> Lastly, TSCE has no reasonable probability of getting back any amounts paid to ICOP after the Quantum Hearing because “ICOP is a shell company”.<sup>315</sup>

---

<sup>312</sup> DCS at paras 567–568.

<sup>313</sup> DCS at paras 569–571.

<sup>314</sup> DCS at paras 566, 572–575.

<sup>315</sup> DCS at paras 576–579.

164 ICOP responds that it is inappropriate for TSCE to “apply” for a stay of execution by closing submissions without a supporting affidavit, and without an opportunity for ICOP to respond. It submits that stays of execution need to be made by way of summons at the time judgment is given, citing O 47 r 1(1) of the Rules of Court (2014 Rev Ed) (the “Old ROC”). Further, ICOP also calls attention to the fact that the bifurcation application was made by TSCE late in the day, and it therefore should not be permitted to “engineer a stay through its own conduct”.<sup>316</sup>

165 I reject TSCE’s fourth submission. There is no evidence that ICOP would not honour or would not be able to honour any judgment made against it after the Quantum Hearing, and such an allegation was not canvassed before me. I also reject ICOP’s reliance on O 47 r 1(1) of the Old ROC. The rule concerns judgments given for the “payment by any person of money”. The necessary implication of the rule is that the judgment is immediately enforceable against the judgment debtor. However, the court retains the discretion to give a judgment which is not immediately enforceable.

166 Taking the parties remaining arguments into account, my decision is that a stay of execution should be granted. Chiefly, I rely on *Cheng Poh Building Construction Pte Ltd v First City Builders Pte Ltd* [2003] 2 SLR(R) 170 (“*Cheng Poh*”) where the Court of Appeal remarked at [11]:

It is settled law that where claims and counterclaims arise out of the same transaction, and while the claims are admitted and the counterclaims are disputed, then so long as the counterclaims are plausible, the correct order to make would be that while judgment should be entered in respect of the claims, it should be stayed pending trial of the counterclaims: see *Sheppards & Co v Wilkinson & Jarvis* (1889) 6 TLR 13. But where a counterclaim does not arise from the same transaction,

---

<sup>316</sup> PRS at paras 219–221.

or is not connected therewith, different rules apply: *eg, Anglian Building Products Ltd v W&C French (Construction) Ltd* (1978) 16 BLR 6, and *AB Contractor Ltd v Flaherty Brothers Ltd* (1978) 16 BLR 10.

167 Although *Cheng Poh* was concerned with summary judgments, my view is that the same considerations apply in respect of bifurcated suits involving claims and counterclaims, as in this case. Further, and more fundamentally, it is unproductive for ICOP to enforce my award at this stage when there is a chance that the net award may ultimately go in TSCE's favour. Such an outcome would render enforcement wholly superfluous and wasteful. However, in the event that TSCE is *not* ultimately successful, there is room for ICOP to be compensated by way of an award of interest. That being said, I reserve my decision in respect of the appropriate order of interest until after the Quantum Hearing.

168 I will also hear parties on costs after the Quantum Hearing.

Lee Seiu Kin  
Judge of the High Court

Lee Wei Han Shaun, Ng Khim Loong Mark, Low Zhe Ning and  
Jonathan Choo (Bird & Bird ATMD LLP) for the plaintiff;  
Ho Chien Mien, Reuben Gavin Peter, Hannah Chua and Yew Kai  
Ning Sophia (Allen & Gledhill LLP) for the defendants.

---



Annex 1: Applicable Baseline Programme

PUB		PROPOSED 2000/1600MM POTABLE WATER ELINE FROM JALAN KAMPUNG CHANTEK TO MARINA SOUTH AND RIVER VALLEY ROAD - PACKAGE 5 (PROPOSED 1600MM PIPELINE FROM AYE/HENDERSON ROAD TO RIVER VALLEY ROAD) MICROTUNNELLING PIPE JACKING WORKS - COMPLIANCE WORK PROGRAM				ICOP	
ID	WorkCode	Task Name	Duration	Start	Finish	Predecessors	
1		Compliance PROPOSED 2000/1600MM DIAMETER POTABLE WATER PIPELINE FROM JALAN KAMPUNG CHANTEK TO MARINA SOUTH (ICOP AND RIVER VALLEY ROAD - PACKAGE 5) (PROPOSED 1600MM DIAMETER PIPELINE FROM AYE/HENDERSON ROAD TO RIVER VALLEY ROAD) MICROTUNNELLING WORKS (W3N-PW3150282)	426 days	Fri 29/12/17	Tue 7/5/19		
2	1.1	CONSTRUCTION PHASE	403 days	Fri 29/12/17	Wed 17/4/19		
3	1.1.1	Notice to proceed by TSC (P5SFT/CON/LICOP/122017/0003) dated 28th December 2018 (Received on 29th December 2018)	0 days	Fri 29/12/17	Fri 29/12/17		
4	1.1.2	Pipe jacking (by ICOP)	358 days	Sat 24/2/18	Wed 17/4/19		
5	1.1.2.1	DN1600	358 days	Sat 24/2/18	Wed 17/4/19		
6	1.1.2.1.1	PS-2 to PS-1 (872m) - 131 Calendar Days	113 days	Sat 24/2/18	Thu 5/7/18		
7	1.1.2.1.1.1	Safety-In / Security-In	2 days	Sat 24/2/18	Mon 26/2/18, 3PS-45 days		
8	1.1.2.1.1.2	Survey Works	1 day	Tue 27/2/18	Tue 27/2/18, 7		
9	1.1.2.1.1.3	Mobilization of Equipment on Site	15 days	Wed 28/2/18	Fri 16/3/18		
10	1.1.2.1.1.4	Setting up of Separation Plant	5 days	Sat 17/3/18	Thu 22/3/18, 9		
11	1.1.2.1.1.5	Setting up of Cogeneration Plant	3 days	Fri 23/3/18	Mon 26/3/18, 10		
12	1.1.2.1.1.6	Setting up of Satellite Office	1 day	Tue 27/3/18	Tue 27/3/18, 11		
13	1.1.2.1.1.7	Setting up of Jacking Equipment in Shaft	7 days	Wed 28/3/18	Wed 4/4/18, 12		
14	1.1.2.1.1.8	Commissioning & testing of all setup including TBM on site	1 day	Thu 5/4/18	Thu 5/4/18, 13		
15	1.1.2.1.1.9	Launching of TBM	1 day	Fri 6/4/18	Fri 6/4/18, 14		
16	1.1.2.1.1.10	Pipe Jacking Works (12m/WC)	66 days	Sat 7/4/18	Fri 22/6/18, 15		
17	1.1.2.1.1.11	TBM Breakthrough and Recovery Works	1 day	Sat 23/6/18	Sat 23/6/18, 16		
18	1.1.2.1.1.12	Tunnel Demolitionization & Grouting Works	10 days	Mon 25/6/18	Thu 5/7/18, 17		
19	1.1.2.1.1.13	Handover Shaft PS-1 to TSC	0 days	Thu 5/7/18	Thu 5/7/18, 18		
20	1.1.2.1.2	PS-2 to PS-3 (826m) - 166 Calendar Days	86 days	Fri 6/7/18	Sat 3/8/18		
21	1.1.2.1.2.1	Survey Works	1 day	Fri 6/7/18	Fri 6/7/18, 13		
22	1.1.2.1.2.2	Turn Around Setting up in Shaft	10 days	Sat 7/7/18	Wed 18/7/18, 21		
23	1.1.2.1.2.3	Commissioning & testing of all setup including TBM on site	1 day	Thu 19/7/18	Thu 19/7/18, 22		
24	1.1.2.1.2.4	Launching of TBM	1 day	Fri 20/7/18	Fri 20/7/18, 23		
25	1.1.2.1.2.5	Pipe Jacking Works (12m/WC)	60 days	Sat 21/7/18	Fri 26/9/18, 24		
26	1.1.2.1.2.6	TBM Breakthrough and Recovery Works	1 day	Sat 29/9/18	Sat 29/9/18, 25		
27	1.1.2.1.2.7	Tunnel Demolitionization & Grouting Works	10 days	Mon 1/10/18	Thu 11/10/18, 26		
28	1.1.2.1.2.8	Site demobilization	7 days	Fri 12/10/18	Fri 19/10/18, 27		
29	1.1.2.1.2.9	Safety-Out / Security-Out	1 day	Sat 20/10/18	Sat 20/10/18, 28		
30	1.1.2.1.2.10	Handover Shaft PS-2 to TSC	0 days	Sat 20/10/18	Sat 20/10/18, 29		
31	1.1.2.1.3	PS-4 to PS-3 (934m) - 179 Calendar Days	154 days	Sat 20/10/18	Wed 17/4/19		
32	1.1.2.1.3.1	Safety-In / Security-In	2 days	Sat 20/10/18	Mon 22/10/18, 28		
33	1.1.2.1.3.2	Survey Works	1 day	Tue 23/10/18	Tue 23/10/18, 32		
34	1.1.2.1.3.3	Mobilization of Equipment on Site	7 days	Wed 24/10/18	Wed 31/10/18, 33		
35	1.1.2.1.3.4	Construction of Gantry Crane foundation and erection of Gantry Crane (including testing, commissioning & permit)	7 days	Thu 11/11/18	Thu 8/11/18, 34		
36	1.1.2.1.3.5	Setting up of Separation Plant	7 days	Fri 9/11/18	Fri 16/11/18, 35		
37	1.1.2.1.3.6	Setting up of Cogeneration Plant	3 days	Sat 17/11/18	Tue 20/11/18, 36		
38	1.1.2.1.3.7	Setting up of Satellite Office	1 day	Wed 21/11/18	Wed 21/11/18, 37		
39	1.1.2.1.3.8	Setting up of Jacking Equipment in Shaft	7 days	Thu 22/11/18	Thu 29/11/18, 38		
40	1.1.2.1.3.9	Commissioning & testing of all setup including TBM on site	1 day	Fri 30/11/18	Fri 30/11/18, 39		
41	1.1.2.1.3.10	Launching of TBM	1 day	Sat 1/12/18	Sat 1/12/18, 40		
42	1.1.2.1.3.11	Pipe Jacking Works (12m/WC)	93 days	Mon 3/12/18	Wed 20/3/19, 41		
43	1.1.2.1.3.12	TBM Breakthrough and Recovery Works	1 day	Thu 21/3/19	Thu 21/3/19, 42		
44	1.1.2.1.3.13	Tunnel Demolitionization & Grouting Works	15 days	Fri 22/3/19	Mon 8/4/19, 43		
45	1.1.2.1.3.14	Site demobilization	7 days	Tue 9/4/19	Tue 16/4/19, 44		
46	1.1.2.1.3.15	Safety-Out / Security-Out	1 day	Wed 17/4/19	Wed 17/4/19, 45		
47	1.1.2.1.3.16	Handover Shaft PS-3 to TSC	0 days	Wed 17/4/19	Wed 17/4/19, 46		
48	1.1.2.1.3.17	Handover Shaft PS-4 to TSC	0 days	Wed 17/4/19	Wed 17/4/19, 47		
49	1.2	COMPLETION & HANDOVER PHASE	25 days	Tue 3/4/19	Tue 17/5/19		
50	1.2.1	Preliminary Inspection before Handover for other works	15 days	Tue 9/4/19	Thu 25/4/19, 44		
51	1.2.2	Practical Completion	7 days	Fri 26/4/19	Fri 3/5/19, 50		
52	1.2.3	Subcontract Completion	0 days	Tue 7/5/19	Tue 7/5/19/5/19/5-3 days		

Revision 02 (ICS/C1382-PS/G/15.6/TSC/L058)

Submission Date: 8th Jan 2018

